



IEEE Recommended Practice for Preparation of Equipment Specifications for Speed-Governing of Hydraulic Turbines Intended to Drive Electric Generators

IEEE Power Engineering Society

Sponsored by the
Energy Development and Power Generation Committee

125TM

IEEE
3 Park Avenue
New York, NY 10016-5997, USA
26 October 2007

IEEE Std 125TM-2007
(Revision of
IEEE Std 125-1988)

IEEE Recommended Practice for Preparation of Equipment Specifications for Speed-Governing of Hydraulic Turbines Intended to Drive Electric Generators

Sponsor

**Energy Development and Power Generation Committee
of the
IEEE Power Engineering Society**

Approved 7 June 2007

IEEE-SA Standards Board

Abstract: This recommended practice is intended to assist users with the preparation of procurement specifications for electric-hydraulic speed governors.

Keywords: control, digital, governor, hydraulic, hydroelectric, speed, stability

The Institute of Electrical and Electronics Engineers, Inc.
3 Park Avenue, New York, NY 10016-5997, USA

Copyright © 2007 by the Institute of Electrical and Electronics Engineers, Inc.
All rights reserved. Published 26 October 2007. Printed in the United States of America.

IEEE is a registered trademark in the U.S. Patent & Trademark Office, owned by the Institute of Electrical and Electronics Engineers, Incorporated.

Print: ISBN 0-7381-5637-X SH95699
PDF: ISBN 0-7381-5638-8 SS95699

No part of this publication may be reproduced in any form, in an electronic retrieval system or otherwise, without the prior written permission of the publisher.

IEEE Standards documents are developed within the IEEE Societies and the Standards Coordinating Committees of the IEEE Standards Association (IEEE-SA) Standards Board. The IEEE develops its standards through a consensus development process, approved by the American National Standards Institute, which brings together volunteers representing varied viewpoints and interests to achieve the final product. Volunteers are not necessarily members of the Institute and serve without compensation. While the IEEE administers the process and establishes rules to promote fairness in the consensus development process, the IEEE does not independently evaluate, test, or verify the accuracy of any of the information contained in its standards.

Use of an IEEE Standard is wholly voluntary. The IEEE disclaims liability for any personal injury, property or other damage, of any nature whatsoever, whether special, indirect, consequential, or compensatory, directly or indirectly resulting from the publication, use of, or reliance upon this, or any other IEEE Standard document.

The IEEE does not warrant or represent the accuracy or content of the material contained herein, and expressly disclaims any express or implied warranty, including any implied warranty of merchantability or fitness for a specific purpose, or that the use of the material contained herein is free from patent infringement. IEEE Standards documents are supplied “**AS IS.**”

The existence of an IEEE Standard does not imply that there are no other ways to produce, test, measure, purchase, market, or provide other goods and services related to the scope of the IEEE Standard. Furthermore, the viewpoint expressed at the time a standard is approved and issued is subject to change brought about through developments in the state of the art and comments received from users of the standard. Every IEEE Standard is subjected to review at least every five years for revision or reaffirmation. When a document is more than five years old and has not been reaffirmed, it is reasonable to conclude that its contents, although still of some value, do not wholly reflect the present state of the art. Users are cautioned to check to determine that they have the latest edition of any IEEE Standard.

In publishing and making this document available, the IEEE is not suggesting or rendering professional or other services for, or on behalf of, any person or entity. Nor is the IEEE undertaking to perform any duty owed by any other person or entity to another. Any person utilizing this, and any other IEEE Standards document, should rely upon the advice of a competent professional in determining the exercise of reasonable care in any given circumstances.

Interpretations: Occasionally questions may arise regarding the meaning of portions of standards as they relate to specific applications. When the need for interpretations is brought to the attention of IEEE, the Institute will initiate action to prepare appropriate responses. Since IEEE Standards represent a consensus of concerned interests, it is important to ensure that any interpretation has also received the concurrence of a balance of interests. For this reason, IEEE and the members of its societies and Standards Coordinating Committees are not able to provide an instant response to interpretation requests except in those cases where the matter has previously received formal consideration. At lectures, symposia, seminars, or educational courses, an individual presenting information on IEEE standards shall make it clear that his or her views should be considered the personal views of that individual rather than the formal position, explanation, or interpretation of the IEEE.

Comments for revision of IEEE Standards are welcome from any interested party, regardless of membership affiliation with IEEE. Suggestions for changes in documents should be in the form of a proposed change of text, together with appropriate supporting comments. Comments on standards and requests for interpretations should be addressed to:

Secretary, IEEE-SA Standards Board
445 Hoes Lane
Piscataway, NJ 08854
USA

Authorization to photocopy portions of any individual standard for internal or personal use is granted by the Institute of Electrical and Electronics Engineers, Inc., provided that the appropriate fee is paid to Copyright Clearance Center. To arrange for payment of licensing fee, please contact Copyright Clearance Center, Customer Service, 222 Rosewood Drive, Danvers, MA 01923 USA; +1 978 750 8400. Permission to photocopy portions of any individual standard for educational classroom use can also be obtained through the Copyright Clearance Center.

Introduction

This introduction is not part of IEEE Std 125-2007, IEEE Recommended Practice for Preparation of Equipment Specifications for Speed-Governing of Hydraulic Turbines Intended to Drive Electric Generators.

This recommended practice assists users with procurement specifications for turbine governing systems for hydroelectric generating units. It is recommended this document be used in conjunction with companion document IEEE Std 1207™.^a This recommended practice is designed to be a reference document for practicing engineers in the hydroelectric industry and offers guidance for what elements of a turbine governing system need to be specified.

Notice to users

Errata

Errata, if any, for this and all other standards can be accessed at the following URL: <http://standards.ieee.org/reading/ieee/updates/errata/index.html>. Users are encouraged to check this URL for errata periodically.

Interpretations

Current interpretations can be accessed at the following URL: <http://standards.ieee.org/reading/ieee/interp/index.html>.

Patents

Attention is called to the possibility that implementation of this recommended practice may require use of subject matter covered by patent rights. By publication of this recommended practice, no position is taken with respect to the existence or validity of any patent rights in connection therewith. The IEEE shall not be responsible for identifying patents or patent applications for which a license may be required to implement an IEEE standard or for conducting inquiries into the legal validity or scope of those patents that are brought to its attention.

^a For more information about this IEEE standard, please see Clause 2.

Participants

At the time this recommended practice was submitted to the IEEE-SA Standards Board for approval, the Energy Development and Power Generation Committee Working Group had the following membership:

David Apps, *Chair*
David L. Kornegay, *Vice Chair*

J. C. Agee
Terry Bauman
Steven R. Brockschink
Matthew T. Davis
Terry Deckman
Donald Evans

Russ Fostiak
George Girgis
Tony Griffiths
Randall C. Groves
James H. Gurney
Hans Naeff
Bernard Poulin

Douglas Seely
Chris Shultz
Philip Spotts
Winfried Stach
Wayne Timm
John B. Yale

The following members of the balloting committee voted on this recommended practice. Balloters may have voted for approval, disapproval, or abstention.

William J. Ackerman
J. C. Agee
S. K. Aggarwal
David B. Apps
Ali Al Awazi
Steven R. Brockschink
Tommy P. Cooper
Luis M. Coronado
Matthew T. Davis
Bostjan K. Derganc

Gary R. Engmann
J. Travis Griffith
Randall C. Groves
James H. Gurney
Gary A. Heuston
David A. Horvath
Innocent Kamwa
Joseph L. Koepfinger
David L. Kornegay
Lawrence D. Long
Willaim Lumpkins

John W. Martin
Don G. McLaren
Gary L. Michel
Michael S. Newman
Bartien Sayogo
Gil Shultz
William W. Terry
Wayne Timm
James W. Wilson
Theodore C. Zeiss

When the IEEE-SA Standards Board approved this recommended practice on 7 June 2007, it had the following membership:

Steve M. Mills, *Chair*
Robert M. Grow, *Vice Chair*
Don Wright, *Past Chair*
Judith Gorman, *Secretary*

Richard DeBlasio
Alex Gelman
William R. Goldbach
Arnold M. Greenspan
Joanna N. Guenin
Julian Forster*
Kenneth S. Hanus
William B. Hopf

Richard H. Hulett
Hermann Koch
Joseph L. Koepfinger*
John Kulick
David J. Law
Glenn Parsons
Ronald C. Petersen
Tom A. Prevost

Narayanan Ramachandran
Greg Ratta
Robby Robson
Anne-Marie Sahazizian
Virginia C. Sulzberger
Malcolm V. Thaden
Richard L. Townsend
Howard L. Wolfman

*Member Emeritus

Also included are the following nonvoting IEEE-SA Standards Board liaisons:

Satish K. Aggarwal, *NRC Representative*
Alan H. Cookson, *NIST Representative*

Jennie M. Steinhagen
IEEE Standards Program Manager, Document Development

Matthew J. Ceglia
IEEE Standards Program Manager, Technical Program Development

Contents

1. Overview	1
1.1 Scope	1
1.2 Purpose	1
1.3 Disclaimer	1
1.4 Use of IEEE Std 125	2
2. Normative references	2
3. Definitions	3
4. Functions and characteristics	4
4.1 Control actuator position	4
4.2 Control actuator stroke	4
4.3 Control actuator time	4
5. Equipment specifications	5
5.1 General specifications	5
5.2 Governor and auxiliary functions	7
5.3 Other optional functions	14
5.4 Hydraulic pressure supply system	16
5.5 New installation considerations	21
5.6 Replacement and conversion considerations	22
5.7 Redundancy	23
5.8 Failsafe features	23
5.9 Dual-regulated turbines	24
5.10 Additional governor-controller functions	26
5.11 Environmental specifications	27
5.12 Software	28
5.13 Interface to other plant systems	29
5.14 Operator interface	30
5.15 Personnel safety features	30
5.16 Spare parts and accessories	31
5.17 Product support	32
6. Performance specification	32
6.1 Stability	32
6.2 Permanent speed droop	34
6.3 Deadband	34
6.4 Deadtime	35
6.5 Governor damping adjustments	35
7. Information provided by the manufacturer	36
7.1 Information to be provided at the time of submission of proposals	36
7.2 Information to be provided after contract award	36
7.3 Test procedures	37
7.4 Rehabilitation and conversion considerations	38
8. Governor testing	38
8.1 Factory acceptance testing	38
8.2 On-site acceptance testing	39

9. Information provided by the specifier	41
Annex A (informative) Bibliography	44
Annex B (informative) Glossary	46
Annex C (normative) Mode control logic	47
C.1 Droop mode control logic	47
C.2 Governor mode control logic	47
Annex D (normative) Tables	49

IEEE Recommended Practice for Preparation of Equipment Specifications for Speed-Governing of Hydraulic Turbines Intended to Drive Electric Generators

1. Overview

1.1 Scope

This document recommends performance characteristics and equipment for electric-hydraulic governors for all types of hydraulic turbines intended to drive electric generators of all sizes. This recommended practice is applicable to new governors and rehabilitation of existing governors.

1.2 Purpose

This recommended practice is intended to assist users with the preparation of procurement specifications for electric-hydraulic speed governors.

1.3 Disclaimer

This recommended practice is intended to help users develop the technical portion of procurement specifications for electric-hydraulic speed governors. It does not cover the commercial portion of the procurement specification. It does not cover governor equipment installation procedures.

1.4 Use of IEEE Std 125

This recommended practice should be used in conjunction with IEEE Std 1207TM.¹ IEEE Std 125 provides recommendations regarding performance characteristics and equipment specifications relating to turbine governing systems for controlling hydroelectric units. IEEE Std 1207 provides application insight for applying these systems to hydroelectric units and offers experience-based guidance on the impact upon system performance of various specification parameters of turbine governing systems. In addition to providing recommendations regarding performance characteristics, it is the intent of the IEEE Std 125 to provide aid in preparing technical specifications for turbine governing systems for controlling hydroelectric units. Incorporation of the technical specifications contained in IEEE Std 125 into a user organization's specification document is left to the user's discretion with respect to organization and sequence.

Features and tests detailed in Clause 5, Clause 6 and Clause 8 of this document are considered either "recommended" or "optional." The appearance of the words "should" implies this feature, function or test is recommended for all installations. The appearance of the words "may" implies this feature, function or test is optional (at the specifier's discretion). Optional items are often not implemented in the majority of installations, but may be required by some purchasers depending on their operating experience and design philosophy.

The following example shows typical wording for a recommended feature:

"The governor-control system should provide a means for controlling the turbine-control actuators manually." (See 5.2.9.)

The following example shows typical wording for an optional feature:

"A governor-control strategy may be specified in accordance with the anticipated performance requirements of the installation." (See 5.2.1.2.)

This document applies to new governors and governor conversions. IEEE Std 1147TM contains a general overview of governor conversions. Only those paragraphs in IEEE Std 125 that apply to the specific equipment to be purchased should be used when preparing the procurement specification.

2. Normative references

The following referenced documents are indispensable for the application of this document (i.e., they must be understood and used, so each referenced document is cited in text and its relationship to this document is explained). For dated references, only the edition cited applies. For undated references, the latest edition of the referenced document (including any amendments or corrigenda) applies.

IEEE Std 1010TM, IEEE Guide for Control of Hydroelectric Power Plants.^{2, 3}

IEEE Std 1147TM, IEEE Guide for the Rehabilitation of Hydroelectric Power Plants.

IEEE Std 1207TM, IEEE Guide for the Application of Turbine Governing Systems for Hydroelectric Generating Units.

¹ Information on references can be found in Clause 2.

² The IEEE standards or products referred to in Clause 2 are trademarks owned by the Institute of Electrical and Electronics Engineers, Incorporated.

³ IEEE publications are available from the Institute of Electrical and Electronics Engineers, 445 Hoes Lane, Piscataway, NJ 08855-1331, USA (<http://standards.ieee.org/>).

3. Definitions

For the purposes of this recommended practice, the following terms and definitions apply. The glossary in Annex B and *The Authoritative Dictionary of IEEE Standards* [B17],⁴ should be referenced for terms not defined in this clause.

3.1 control actuator limit: A maximum limit within the governor system which prevents the turbine-control actuator from opening beyond the position for which the device is set. May be operator-adjustable.

3.2 control actuator velocity limiter: A device that functions to limit the control actuator velocity in either the opening, closing, or both directions, exclusive of the operation of the slow closure device. *See also:* **slow closure device.**

3.3 executable code: The software code that resides in the digital controller and executes the control sequence/strategy in real time.

3.4 governor controller: A device or system that compares the turbine speed, along with any applicable intermediate feedbacks, to a reference set point and processes the resultant error signal to produce a command signal to the turbine-control actuator.

3.5 governor conversion: Replacement of the governor controller components of an existing governor, typically with a digital controller and new speed and turbine-control actuator position-sensing equipment.

3.6 grid connected: The condition where the turbine-generator unit is electrically connected to a large power grid consisting of many turbine-generator units operating in parallel.

3.7 hydraulic power unit (HPU): The pumps, means for driving them, sump tank, and associated accessory devices.

3.8 hydraulic pressure supply system (HPSS): The hydraulic power unit (HPU), pressure tank(s), valves, and piping connecting the various parts of the governing system.

3.9 main servomotor: The primary servomotor used to control the primary turbine-control device. For reaction turbines, the main servomotor controls the wicket gates. For impulse turbines, the main servomotor controls the deflectors. For dual-regulated turbines, the main servomotor is typically larger and faster than the secondary servomotor.

3.10 programming computer: The computer that generates and stores the source code. It is also used to download the executable code and operate the various software tools and utilities.

3.11 settings: The various user-adjustable parameters that reside in the digital controller such as time constants, gains, thresholds, etc. These are also known in the industry as tunables or constants.

3.12 slow closure device: A cushioning device that retards the closing velocity of the control actuator from a predetermined control actuator position to zero control actuator position.

3.13 speed-sensing elements: The speed responsive elements that determine speed and influence the action of other elements of the governing system. Included are the means used to transmit a signal proportional to the speed of the turbine to the governor.

3.14 speed error: The algebraic difference between the speed reference and the measured turbine speed.

⁴ The numbers in brackets correspond to those in the bibliography in Annex A.

3.15 turbine-control actuator: A device or system that controls the position of a turbine-control device in response to a command signal from the governor controller. Examples include: electric motor-driven actuator; hydraulic-control actuator and associated distributing valve.

3.16 turbine-control device: An adjustable device that directly affects the operation of the hydraulic turbine. Some examples of turbine-control devices are wicket gates, runner blades, flow-controlling orifices (or “nozzles”), and deflectors.

3.17 turbine-control actuator rating: The turbine-control actuator rating is the flow rate in volume per unit time that the turbine-control actuator can deliver at a specified pressure drop. The pressure drop should be measured across the terminating pipe connections to the turbine-control actuators at the actuator. This pressure drop is measured with the specified minimum normal working pressure of the HPSS delivered to the supply port of the actuator distributing valve.

4. Functions and characteristics

For purposes of this document, the functions and characteristics discussed in 4.1, 4.2, and 4.3 apply. IEEE Std 1207 should be referenced for functions and characteristics not defined in this clause.

4.1 Control actuator position

The instantaneous position of the turbine-control actuator measured from its zero position expressed as a percentage of the control actuator stroke. This is commonly referred to as gate position, nozzle position, blade position, or deflector position, although the relationship between control actuator stroke and the position of the controlled device may not always be linear.

4.2 Control actuator stroke

Travel of the turbine-control actuator (in inches or mm) from minimum (zero without squeeze) position to maximum position (without overtravel). This is sometimes referred to as “effective control actuator stroke.” For a gate or nozzle control actuator this is defined as the travel of the control actuator required to change the gate or nozzle position from no discharge to maximum discharge. For a blade control actuator this is defined as the travel of the control actuator required to change the blade position from “flat” to “steep.” For a deflector-control actuator this is defined as the travel of the control actuator required to change the deflector position from the “no deflection” position to the “full flow deflected” position with maximum discharge under maximum specified head, including overpressure due to water hammer.

4.3 Control actuator time

The elapsed time for one full control actuator stroke (either opening or closing) at maximum control actuator velocity. The control actuator time is equal to 100 divided by the maximum control actuator velocity (velocity expressed in units of percent per second) and is typically measured over a reduced range (for example, 25% to 75%) to eliminate the effect of cushioning.

5. Equipment specifications

5.1 General specifications

5.1.1 Interface to other plant equipment

For new unit supply, the manufacturer of the governor equipment should cooperate to the fullest extent possible with the manufacturers of the turbine and generator equipment to ensure that the purchaser is furnished with a complete and properly coordinated governor-control system capable of functioning to properly regulate the speed and power output of the turbine and generator.

For governor replacements and conversions, the manufacturer of the governor equipment is responsible for ensuring that the equipment will interface both mechanically and electrically to the existing plant equipment. Visits to the site by the manufacturer may be required to confirm compatibility between existing and proposed equipment and to confirm dimensions shown on existing plant equipment drawings.

5.1.2 Governor operation

Unless otherwise specified, the governor-control system should be supplied as a complete system, including speed-sensing elements, governor-control cabinet, governor hydraulic-control valve, HPSS, and all specified parts and accessories required to control the speed and generation of the hydroelectric generating unit. The rating of the governor hydraulic-control valve should be sufficient to operate the turbine-control actuators within the specified control actuator timing parameters.

This recommended practice primarily focuses upon using hydraulic turbine-control actuators, which are very commonly used for hydroelectric turbines. However, the functional characteristics specified also apply to any other type of turbine-control actuator that may be used in a particular application (e.g., electric actuators).

5.1.3 Governor cabinet construction

The governor-control equipment should be housed in a cabinet that provides physical protection, electrical shielding and protection from contaminants such as dust and oil. The specification writer may include detailed requirements related to cabinet size, material, paint type and color, grounding, cable access, seismic withstand, wiring and wire termination. Steel and aluminum are commonly specified cabinet materials. The governor electronic control cabinet may either be mounted on the hydraulic power unit, or it may be mounted at a separate location.

5.1.4 Nameplate

A permanent metal nameplate should be provided on each governor-control cabinet, clearly marked or stamped to indicate the following information:

- Manufacturer's name and address
- Serial number of the governor-control system
- Model number and type number of the governor-control system
- Date of manufacture

- Maximum working hydraulic supply pressure
- Minimum normal working hydraulic supply pressure
- Rated hydraulic fluid flow at the minimum normal working hydraulic supply pressure

5.1.5 Electrical power

The purchaser will make available uninterruptible direct current (dc) or alternating current (ac) control power from the station's battery or UPS system within a specified range of voltage. All critical control devices including solenoids, relays, electronic controls, and power supplies used within the governor-control system should be operable within the stated control power voltage range.

The purchaser will also make available three-phase and single-phase station service ac (SSAC) power within stated voltage ranges. These SSAC power sources will be subject to transient overfrequency and overvoltage conditions following a separation of the station from the interconnected power system. All governor-control system components utilizing the SSAC power sources should be designed to withstand these transient conditions without damage and without mis-operation.

Assuming that adequate hydraulic pressure exists and control power is available, it should be possible to start the turbine generator without SSAC power.

5.1.6 Power supplies

A reliable power supply system should be provided for powering the governor electronic control circuitry. The preferred power supply system should include redundant power supplies connected to separate power sources within the station such that the failure of any one regulated output voltage should cause instantaneous transfer to a redundant supply without affecting normal governor operation in any way. Alarm indication should be provided to indicate the failure of one of the redundant power supplies. If non-redundant power supplies are specified, proper fail-safe operation of the governor control in the event of a power supply failure should also be specified. The manufacturer of the governor system should provide full details of the proposed power supply system for approval by the purchaser. A common design philosophy for redundant power supply systems powers one redundant power supply from the station service ac source, and one redundant power supply from the station dc battery system. This approach accommodates the fact that the ac power source is not considered secure, and the dc power source is always available to act as a backup to the ac power source.

5.1.7 Test facilities

5.1.7.1 Isolation and test switches

The specifier may specify isolation and test switches to facilitate testing during commissioning or maintenance. The quantity, circuit location and physical location should be clearly indicated.

5.1.7.2 Signal monitoring

If a digital controller is specified, analog outputs may be provided for purposes of monitoring internal variables with the purchaser's recording device. The bandwidth of each analog output should be specified (10 Hz or higher typical). Alternatively, this capability may be provided by way of having the governor controller automatically record the internal variables. The recording rate should be user adjustable. The fastest recording rate (10 samples per second typical) and the minimum number of samples (1000 typical) should be specified.

It should be possible for the user to select any combination of variables for recording from a preset menu or list. The quantity and variable names should be clearly indicated. The following variables are typical:

- Main turbine-control actuator (gate or deflector) position
- Main turbine-control actuator (gate or deflector) set point
- Blade or nozzle servomotor position (if applicable)
- Blade or nozzle servomotor set point (if applicable)
- Speed
- Speed error (input to damping element)
- Turbine-control actuator limit setting

5.1.7.3 Signal injection

A specified quantity (typically two) of analog inputs may be specified for purposes of external live-signal injection for test purposes. The bandwidth of the analog inputs should be a minimum of 10 Hz. It should be possible to sum the injected signal at various user-selectable points inside the governor controller. Typical injection points include the following:

- Speed-error summing point
- Active-power summing point (if applicable)

5.2 Governor and auxiliary functions

5.2.1 Governor control

5.2.1.1 Speed error

Measurement of turbine speed is a basic requirement of a speed-governing system. The governors specified in accordance with this recommended practice should measure the speed of turbine rotation and compare this measured speed with the governor speed reference to produce a speed error. The speed error is used to develop a controlling output to the turbine-control devices according to the chosen governor-control strategy in order to regulate the speed and power output of the hydraulic turbine/generator to satisfy the specified performance criteria.

NOTE—The term “speed reference” is also commonly known as a speed changer or speed set point.⁵

5.2.1.2 Governor-control strategy

A governor-control strategy is a basic requirement of a speed-governing system. A governor-control strategy may be specified in accordance with the anticipated performance requirements of the installation. The strategy consists of processing the speed error signal (see 5.2.1.1), applying speed droop and finally

⁵ Notes in text, tables, and figures of a standard are given for information only and do not contain requirements needed to implement this standard.

applying a suitable damping scheme, which is used to control the turbine-control actuator(s). The strategy may include switching between different control modes (see 5.2.3).

Some common damping strategies are:

- Temporary droop controller
- Proportional, integral, derivative (PID) controller
- Double derivative controller
- Lead/lag controller

For details regarding damping and control strategies, see Agee et al. [B1] and Eilts et al. [B6] in Annex A and IEEE Std 1207.

Some manufacturers may offer only one of the above damping strategies whereas others many offer more than one strategy. Specifying one particular damping strategy may reduce the competitiveness of the tendering process.

5.2.2 Speed droop

Speed droop is a basic characteristic of a speed-governing system. The speed droop for the governor-control system should be adjustable over the range specified for the application. This adjustment should be adjustable at the governor-control cabinet, and it may be specified to be adjustable from a remote location. The range adjustability is typically 0 to 10%

The speed droop parameter may be derived by control actuator position feedback (historically referred to as simply “speed droop”), in terms of active power feedback (historically referred to as “speed regulation” or sometimes “power droop”), or in terms of flow feedback. For the remainder of this recommended practice, the historical terms will be dropped in favor of the following more precise terms:

- Speed droop-position (speed droop derived via position feedback)
- Speed droop-power (speed droop derived via power feedback)
- Speed droop-flow (speed droop derived via flow feedback)

5.2.3 Control modes

5.2.3.1 Position control

For projects where position control is required, the governor should compare the measured to the desired turbine-control actuator position, multiply this error signal by the droop parameter, and inject the resultant signal into a summing point to adjust the turbine-control actuator(s) accordingly. The measured position typically comes from an analog or digital actuator position-measuring transducer.

5.2.3.2 Power control

For projects where power control is required, the governor should compare the measured to the desired power, multiply this error signal by the droop parameter, and inject the resultant signal into a summing point to adjust the turbine-control actuator(s) accordingly. The measured power typically comes from watt

transducers. The user should specify what automatic actions the governor will take if the power signal is lost.

NOTE—An alternate method of achieving power control is to implement position control via an inner loop and apply the power error signal to an outer loop.

5.2.3.3 Flow control

For projects where flow control is required, the governor should compare the measured to the desired flow, multiply this error signal by the droop parameter, and inject the resultant signal into a summing point to adjust the turbine-control actuator(s) accordingly. The measured flow typically comes from flow meters or from a look-up table that uses total head along with either wicket gate position or power output to determine the actual flow. The user should specify what automatic actions the governor will take if the flow signal is lost.

NOTE—An alternate method of achieving flow control is to implement position control via an inner loop and apply the flow error signal to an outer loop.

5.2.3.4 Head pond and tail pond control

For projects where head pond or tail pond level control is required, the governor controller should compare the measured pond level to the desired pond and inject this error signal into a summing point to adjust the turbine-control actuator(a) accordingly. The control process should take into account the physical layout of the water system and time delays due to water passage. Due to the critical nature of the feedback from the pond, care should be taken to ensure the reliability of the pond level signal. The user should specify what automatic actions the governor will take if the pond level signal is lost.

5.2.3.5 Pumped storage

A pumped storage facility has additional requirements that should be accurately described in the specification. The following is a list of some of the items that may be required:

- A means of manually controlling gate position while in pump mode
- Gate control actuator positioning as a function of operating head
- Separate control acutator velocity adjustments for pumping operation

For further details of pumped storage controls, see IEEE Std 1010.

5.2.4 Speed reference

The speed reference should be operator-adjustable over the range specified for the application. Typically, the specified range is from 85% of rated speed at no load and zero speed droop to 110% rated speed at maximum control actuator position/power and maximum speed droop. If remote control of the speed reference is required, the time to change the power output setting from maximum to zero or vice versa should be specified. An adjustment range of 20 s to 60 s is typical.

5.2.5 Control actuator limit

The governor-control system should provide a means of limiting the maximum allowable position of the turbine-control actuators, which should be adjustable from zero to full control actuator stroke. The control actuator limit should also be adjustable from a remote location. The provision of an adjustable minimum control actuator position limit may also be specified. The minimum control actuator position limit may be activated or de-activated under certain specified operating conditions such as overspeed, operating with the unit circuit breaker open or while in synchronous condenser mode.

5.2.6 Control actuator velocity or time adjustment

A control actuator velocity adjustment should be provided. Both the maximum opening and closing velocities of the turbine-control actuator should be independently adjustable. Typically, these maximum velocities are expressed in control actuator full stroke operating times. The method of operation should be such that operation of any control, automatic device, or auxiliary device should be able to move the turbine-control actuator at a velocity no greater than that set by these adjustments. The method of adjustment should be specified and should be secure, thereby minimizing the chance of accidental misadjustment. Typical methods include adjustable distributing valve stop nuts, flow restricting orifices and flow control valves.

The opening and closing travel times should be specified and are normally dictated by the permissible water-hammer effect in the water conduit and the permissible overspeed following load rejection. The closing time may also be dictated by the possibility of draft tube water column separation. The opening time may also be dictated by the possibility of surge tank (or surge shaft) air entrainment.

5.2.7 Control actuator position feedback

Control actuator position feedback is a basic requirement of a speed-governing system. The position feedback system is used to transmit the position of the turbine-control actuators to the governor-control system. The response time of the position feedback system should be compatible with the governor performance requirements as specified in Clause 6. The accuracy and resolution of the position feedback system should be specified and should be guaranteed over the operating temperature range specified in 5.11.1. Values of 0.1% for accuracy and 0.02% for resolution have been found through experience to provide acceptable performance.

The position feedback system should be designed such that any failure in the mechanism will cause the turbine-control actuators to respond in the manner specified (for example, force the turbine-control device to fully close).

5.2.8 Speed-sensing source

Speed sensing is a basic requirement of a speed-governing system. The range and response time of the speed-sensing source should be compatible with the governor performance requirements (as specified in Clause 6) and as required for the adjustment range of the speed switches. The accuracy and resolution of the speed-sensing source should be specified and should be guaranteed over the operating temperature range specified in 5.11.1. Values of 0.03% for accuracy and 0.003% for resolution have been found through experience to provide acceptable performance.

Two common approaches to measuring turbine speed are the measurement of the generator output frequency (via voltage transformers for synchronous generators) and speed-measuring devices either coupled to or surrounding the turbine shaft or to the upper end of the generator shaft [for example, toothed wheels using proximity pickups or optical photoelectric sensors or permanent magnet generator (PMG)].

Any speed-measuring device that is coupled to a shaft should be capable of withstanding, without damage, a specified overspeed condition for the turbine.

If the turbine speed is measured via the frequency of the generator's voltage transformer output, the speed-measuring circuitry should be of sufficient sensitivity to measure the turbine speed down to a specified minimum speed, relying only upon residual voltage output from the generator (i.e., without field excitation applied). Appropriate filtering should also be included as part of the generator frequency measurement system to prevent false speed measurements from being computed from high frequency transients that may appear on the generator's voltage transformer, either during off-line or grid-connected operation.

5.2.9 Manual control

The governor-control system should provide a means for controlling the turbine-control actuators manually. When manual control is selected, the control of the turbine-control actuators should respond only to the position set-point command, without any response from the turbine speed or generation level. Transfer between normal governor control and manual control should be accomplished smoothly, without a disturbance in the turbine-control actuator position. It should be possible to move the turbine-control actuators through full stroke in both directions in not more than the maximum time and in not less than the minimum time specified.

If required, a "governor in manual" indication circuit may be provided to the purchaser's protection system to force a shutdown if the turbine is being operated outside the normal governing speed range (i.e., above approximately 105% speed).

5.2.10 Automatic shutdown

The governor-control system should provide the capability of one or more turbine-generator shutdown sequences upon the occurrence of specified operator actions or system occurrences.

- An emergency shutdown sequence should be provided. Emergency shutdown should initiate immediate turbine shutdown and immediate opening of the generator breaker.
- A quick shutdown sequence may be provided. Quick shutdown should initiate immediate turbine shutdown and open the generator breaker at speed-no-load.
- A partial shutdown sequence may be provided. Partial shutdown should initiate rapid closing of the turbine-control actuator to the speed-no-load condition.

Typical shutdown sequence initiations are detailed in 5.2.11 and 5.2.15.

5.2.11 Emergency stop

Provisions for manual emergency stopping of the turbine should be provided. A common arrangement is to provide an emergency stop pushbutton at the governor cabinet and possibly at one or more other locations inside the powerhouse.

A common arrangement is to connect each pushbutton to the purchaser's protection equipment. The protection system should stop the turbine-generator unit by either the emergency shutdown sequence or the quick shutdown sequence (see 5.2.10).

5.2.12 Generator braking system

Manual and automatic brake control may be specified. Automatic operation of the generator brake valve should only be allowed when the turbine-control actuator is fully closed and the turbine speed has decreased below a specified speed. The generator brake control should apply the brakes (continuously/intermittently) until the turbine has come to a complete stop.

An automatic control valve, with provisions for emergency hand operation, should be provided for controlling the operation of the generator braking system. The automatic control valve should be an “energized to apply” circuit and should have power provided by dc (or battery backed ac). The emergency hand operation of the generator brake control should allow latching the brakes in their “applied” position.

5.2.13 Set-point feed forward

A set-point feed forward function should be provided. This feature provides a faster response to set-point (for example, power reference) changes while allowing governor gains to be independently tuned for stable operation.

5.2.14 Switches

All switches should have electrically-separate contact circuits. The form of the contacts should be form A, form B, or form C in accordance with the specifier’s specifications. The contact circuits should be suitable for continuous duty over a specified range of ac or dc voltages (as required by the specifier), and should be capable of interrupting non-inductive circuits at an amperage level as required by the specifier (alternately inductive circuits with specified L/R ratio and amperage). When specified to be readily adjustable, a device should be provided with a method of adjustment that does not require special tools. Where ready accessibility is required, the device should be accessible without the need for removing panels or other equipment.

5.2.14.1 Overspeed switch

A main overspeed switch should be provided that operates at a specified percent of rated turbine speed, and resets at not less than 105% of rated turbine speed. This main overspeed switch may be implemented in a speed switch subsystem that is independent from the main governor-control system. The main overspeed switch may either be mechanically driven from the turbine shaft, or it may be electrically operated by an independent or redundant speed-sensing system. Alternatively, a mechanically-driven hydraulic shutdown system may be specified.

5.2.14.2 Speed switch

A specified number of electrical speed switches should be provided that operate and reset at specified turbine speeds. The “operate” and “reset” speeds for each speed switch should be independently adjustable, and all speed switches should be independently adjustable. Speed switches may be mechanically driven or electrically operated by a speed-sensing system. Some typical speed switches are:

- Generator brake application control
- Excitation system starting and stopping control
- Thrust bearing lift pump starting and stopping control

5.2.14.3 Turbine-control actuator position switch

The specifier may require a number of electrical contacts that operate at specified turbine-control actuator positions, such as fully closed, synchronous no-load position, or fully open. These control actuator position contacts may be specified to be driven from the control actuator position transducer used by the governor controller, or they may be specified as separate, mechanically-driven switch assemblies. Each control actuator position switch should be readily adjustable to operate at any desired position throughout the full range of control actuator travel. Individual switch adjustments should be readily accessible.

5.2.14.4 Hydraulic pressure supply system switch

Adjustable switches to indicate specific oil pressures, oil levels, and oil temperatures within the HPSS should be specified. Switches may be either individual devices (for example, pressure switch) or contact outputs from the governor controller, driven by appropriate transducers. The specifier's preference (if any) should be indicated.

5.2.14.5 Brake supply pressure switch

The specifier may require provision of an electrical contact to indicate when the pressure supply for the generator brake is below normal pressure. The specifier should further specify if a separate pressure switch is required, or if contact outputs from the governor controller, driven by a pressure transducer, are acceptable.

5.2.14.6 Turbine-control actuator limit coincidence switch

The specifier may specify provision of an electrical contact or alarm to indicate when the turbine-control actuator equals the control actuator position limit setting. This contact may be used to block raise commands from affecting the governor set point, thus preventing “windup” of the governor set point beyond a level where the governor is able to respond.

5.2.15 Turbine shutdowns

A safe and orderly shutdown of the turbine should be executed for specified conditions. The following is a typical list of conditions requiring shutdown:

- Failure of the governor controller's main CPU
- Failure of all power supplies
- Failure of all speed signals
- Failure of main control actuator (gate or deflector) position transducer
- Failure of nozzle control actuator position transducer (impulse turbines only)
- Failure of blade control actuator position transducer (adjustable-blade turbines only)
- Nozzle control actuator position mismatch (impulse turbines with two or more nozzles only)
- Oil temperature critical high
- Sump oil level critical low
- Oil pressure critical low

- Accumulator oil level critical high
- Accumulator oil level critical low
- Overspeed
- Electrical and mechanical protection systems external to the governor

5.3 Other optional functions

5.3.1 Rotor creep detection

A rotor creep detecting function may be provided to give an alarm and to initiate protective control action when, upon braking, the rotor of the generator does not come to a complete stop after a suitable time delay, or after having come to a complete stop begins to creep due to brake failure or excessive water leakage, or both. Upon activation, the creep detection function should sense a subsequent angular displacement of 3° of arc or less, without reference to rate of movement. The creep detection system should be immune to turbine-generator unit vibration. It should respond to the creep condition by activating its output and sealing-in until reset by external circuitry. The action upon creep detection will depend on both user practices and the design features of the turbine and turbine-generator bearings. Typical actions include one or more of the following:

- Automatic turbine-generator unit start-up
- Release generator air brakes and start lift pump
- Opening cooling water valve
- Alarm

5.3.2 Deadstop detection

A deadstop sensing function may be provided for indication to an operator that the turbine has reached a deadstop condition. Other possible uses of the deadstop sensing function may include the following:

- Alarm if the turbine should fail to reach a deadstop condition within a preset time
- Automatic shutoff of turbine-generator unit auxiliaries such as a lift pump
- Arming the creep detector

5.3.3 Fire protection system

The specifier may specify the provision of an automatic fire protection system within the governor-control cabinet or the HPSS. The automatic fire protection system may include specified sensors, discharge equipment, and control/alarm system components. The specifier should further specify the applicable standards to which the automatic fire protection system is to be designed, including any requirements imposed by insurers and fire regulations or codes. The design of the system should be coordinated with other fire protection equipment located in the powerhouse.

5.3.4 Turbine-control actuator timing function

A turbine-control actuator timing function may be provided to assist with calibration of the turbine-control actuator velocity limiting device or devices. The timing function should calculate the time it takes for the turbine-control actuator to travel from a preset starting position to a preset end position. The start and end positions should be user-adjustable. The timing function should be operational with the turbine running (for example, load rejection) or during penstock de-watered conditions.

5.3.5 Intelligent alarms

The user may wish to specify one or more intelligent alarms. Intelligent alarms in this context are defined as any alarm that requires some degree of mathematical computation (either simple or complex) in order to determine if an abnormal condition exists. Examples of intelligent alarms include the following:

- Position mismatch between nozzle servomotor positions (impulse turbine) as a method of detecting sticking nozzles.
- Failure of turbine-control actuator feedback to track turbine-control actuator set point.
- Excessive HPSS pump operation or excessive pump operating time.
- Abnormal startup or abnormal shutdown time.
- Isolated operation detection.
- Servomotor pressure unbalance as a method of detecting sticking shift ring (Francis turbine equipped with two or more control actuators). Requires a pressure transducer on each control actuator.
- Value plausibility test, if a value changes faster than theoretically possible.

5.3.6 Fast breakaway

A fast start-up feature may be specified for the purpose of accelerating the turbine at a faster than normal start-up rate. This feature may be used when starting the turbine while the thrust bearing oil lift pump is out of service so as to avoid damage to the thrust bearing.

5.3.7 Isolated operation control

An isolated operation on/off control may be specified for the purpose of operating the turbine-generator unit isolated from the grid. The isolated control may be a manually operated on/off control. Alternately, there may be an isolation detector that automatically places the governor into isolated mode. When in isolated mode, a separate set of gains may be applied and the set-point feed forward (if equipped) should be disabled.

5.3.8 Automatic synchronizing

For the purpose of aiding automatic synchronizing, an automatic speed matching feature may be specified. In addition, automatic voltage-matching and breaker synchronous closing features may be supplied. The speed-matching function is typically accomplished by substituting the governor's normal speed reference with an external speed reference. The external speed reference is typically derived from a switchyard voltage transformer.

The voltage-matching function is typically accomplished by computing an error voltage by subtracting voltages on opposite sides of the open unit circuit breaker. The error signal is used to produce voltage raise and lower pulses which are sent to the exciter.

The synchronous closing function is typically derived by phase angle comparison of the voltages on opposite sides of the open unit circuit breaker. Compensation for breaker closing delay should be specified.

5.3.9 Efficiency optimization

Turbine efficiency optimization may be specified for adjustable-blade units. The efficiency optimization function should monitor the operating head, the generated power, and the flow through the turbine while manipulating the operating gate/blade relationship. When the optimum efficiency for the turbine is achieved, the adjustments to the gate/blade relationship should be stored and utilized by the governor for all future operation of the turbine in the operating region that was optimized.

5.3.10 Trending

The specifier may require a trending feature for purposes of recording and displaying trends of specified variables as a function of time. All required variables (for example, gate position, speed, etc.), the sampling rate, the minimum trend record length, and the minimum quantity of stored records should be specified.

5.4 Hydraulic pressure supply system

Except for turbine-control devices which are electric-motor driven, an HPSS is a basic requirement for a speed-governing system. The HPSS provides the hydraulic pressure used to operate the turbine-control actuators. The HPSS comprises the pressure pumps, the pressure pump motors and starters, the pressure accumulator tank, the sump tank, the automatic gas admission system (if used), and the associated controls, hydraulic piping, and fittings.

5.4.1.1 Pressure pumps and unloaders

The pressure pumps, unless otherwise specified, should be motor-driven, direct-connected positive displacement-type pumps. A pressure relief valve should be provided at the discharge side of each pressure pump that is capable of passing the full delivery flow of the pump to the sump tank when the discharge pressure of the pump exceeds 110% of the nominal system pressure. For critical turbine-generator units (see 5.7 for definition), two main pressure pumps should be provided as part of the HPSS. For non-critical turbine-generator units, a single main pressure pump may suffice. The combined flow capacity of the pressure pumps should be not less than 25% of the flow required by all of the turbine-control actuators combined when traveling at their maximum achievable rate (20% for impulse turbines with a deflector time of less than 2.5 s). A larger flow capacity may be required if the plant is expected to run isolated from the grid. If a continuously-running makeup pump (also known as a jockey pump) is provided as part of the HPSS, the flow of this makeup pump may be included in the combined flow capacity of the pressure pumps when evaluating the pumping capacity of the system. The flow output of the makeup pump, if provided, should be sufficient to supply the steady-state oil consumption of the turbine governing system such that the main pressure pumps will not be required to start during steady-state operation of the turbine. Makeup pumps are most commonly provided on large turbines.

Each pump driven by a motor rated at 7.5 kW or larger should be provided with an unloader valve which returns oil directly to the sump when in the unloaded state. Starting and stopping of the pumps should be in the unloaded condition, thus minimizing the backpressure loading to the pump discharge. All transitions between loaded and unloaded operation of the pump should be timed such that the transition occurs

smoothly in both directions, without any significant impulse loading upon the pump or motor. As an alternative to an unloader valve, each pump may be equipped with a “soft start” motor starter (for example, reduced voltage starter, variable frequency drive) or a pressure-compensated (variable positive displacement) pump.

5.4.2 Pressure pump motors and starters

All requirements for electric motors, motor starters, and related equipment should be specified. As a minimum, the supply voltage available for powering the HPSS should be specified. All electric motors and auxiliary equipment should be capable of withstanding, without damage, expected overvoltage and overfrequency conditions under the following conditions:

- Maximum load rejection of the turbine-generator unit
- Sustained operation of the station, isolated from the interconnected power system

5.4.3 Pump controls

The pump(s) should start automatically when a specified physical quantity (typically pressure) reaches a preset value. Where two main pumps are specified, they should be configured in a lead/lag control strategy. For a pressure-actuated design, the lead pump should start when the system pressure drops to approximately 90% of the nominal system pressure, and stop when the system pressure reaches the nominal system pressure. The lag pump should start when the system pressure drops to approximately 85% of the nominal system pressure, and stop when the system pressure reaches the nominal system pressure.

Provision should be made for pump shutdown under conditions of either high oil temperature or low sump oil level.

Provision should be made for selecting either of the pumps to operate as the lead pump.

The pump control(s) should be designed to automatically restart the pumps after a temporary loss of power.

5.4.4 Motor protection

The pump motors will require branch circuit over-current protection and motor overload protection. Details should be specified and should be in accordance with electrical codes and regulations. Other motor protection functions such as phase reversal, open phase, phase unbalance, and undervoltage may be specified.

5.4.5 Pump control modes

Each pump should have a control to select its mode of operation. The modes of operation available should be as follows:

- Off. In the “Off” mode, the pump is prevented from running.
- Auto. In the “Auto” mode, the pump will automatically start and stop as a function of the system pressure and its lead/lag control selection.
- Continuous. In the “Continuous” mode, the pump will run continuously, loading and unloading as a function of a specified variable (typically pressure) and its lead/lag control selection.

5.4.6 Black start

If the turbine-generator unit is required to have black start capability, a pump supplied by uninterruptible power (battery backed dc or ac) may be specified to be able to build hydraulic pressure sufficient to start the turbine-generator unit during a black start condition. This pump should have sufficient pumping capacity to build the hydraulic pressure up to its nominal system pressure in an acceptable period of time to meet the needs of the black start requirement. Once ac station service has been established, the uninterruptible power pump should be shut down, and the ac-powered pumps should resume normal operation.

5.4.7 HPSS operation on turbine shutdown

Generally, the HPSS runs continuously, maintaining the hydraulic pressure within its normal operating range. This assures that pressure is available to maintain a safe operating and shutdown condition. If the turbine has a fail-safe shutdown device, such as an inlet valve, the HPSS may be shut down after the turbine reaches deadstop and the inlet valve is fully closed. This type of operation reduces the energy consumed by the HPSS, but it also introduces a delay time when starting the turbine-generator unit.

5.4.8 Pressure accumulator tank design

The pressure accumulator tanks should be of welded construction, designed, built, and tested in accordance with the appropriate pressure vessel code (see Annex A for ASME and IEC pressure vessel codes) that is in effect at the time of preparing the specifications for the system to be designed. The supplier of the pressure accumulator tanks should be responsible for obtaining certification of the pressure accumulator tank by the authority of jurisdiction at the site of the installation. The authority of jurisdiction should be specified. If the requirements of the authority of jurisdiction are more stringent than the pressure vessel code, then the authority's requirements shall take precedence.

The pressure accumulator tanks should be supplied with a suitable pressure indication and pressure relief valve.

For gas-over-oil pressure accumulators, a float valve or other positive means of preventing the cushioning gas from entering the hydraulic piping system should be provided as part of the pressure accumulator tank. Appropriately-sized access doors should be provided on the pressure accumulator tank for the purposes of inspecting and cleaning the tank. A tank liquid level indication should be provided.

For transfer barrier accumulator tanks, an anti-extrusion valve should be provided at the bottom of each tank to prevent the barrier from being extruded into the oil port when the barrier has bottomed out. Transfer barrier accumulator tanks include bladder accumulators and piston accumulators.

5.4.9 Pressure accumulator tank sizing

The pressure accumulator tank should be designed such that the hydraulic supply pressure remains above the maximum servomotor differential pressure of the turbine-control actuators at all times when the oil level within the pressure accumulator tank is above the active oil cut-off level (above the float valve closure level in a gas over oil accumulator or bottoming out of the transfer barrier in a transfer barrier accumulator tank).

The pressure accumulator tank should be designed to meet a number of criteria, as detailed in the following list.

- a) Stroke criteria. The pressure accumulator tank should provide a specified minimum number of full strokes (closing direction) of the turbine-control servomotors, commencing at the turbine shutdown pressure, and without any pumps running, before reaching the oil cutoff level. Some common specifications are:
- 1) For a gas-over-oil or piston accumulator, the pressure accumulator tank should provide 1.5 servomotor volumes of oil under these conditions (for a single-regulated turbine), or 1.5 wicket gate servomotor volumes plus one blade servomotor volume in the shutdown direction (for an adjustable-blade turbine), or 1.5 deflector servomotor volumes plus one combined closing nozzle servomotor volume (for an impulse turbine).
 - 2) For a bladder barrier accumulator, the pressure accumulator tank should provide 2.0 servomotor volumes of oil under these conditions (for a single-regulated turbine), or 2.0 wicket gate servomotor volumes plus one blade servomotor volume in the shutdown direction (for an adjustable-blade turbine), or 2.0 deflector servomotor volumes plus one combined closing nozzle servomotor volume (for an impulse turbine).

NOTE—All accumulators follow a polytropic gas law as the gas expands during maximum servomotor velocity conditions. The gas law exponent for bladder barrier accumulators tends to be a higher value than for gas-over-oil accumulators. This is due to the thermal insulating effects of the bladder. For this reason, the classic 1.5 servomotor volume criteria may be insufficient for bladder barrier accumulators.

- b) Minimum pressure criteria. The pressure accumulator tank should provide a specified minimum pressure at the active oil cut-off level. A typical value for the minimum pressure is 75% of nominal pressure (where nominal refers to the pump stop pressure) or 15% above the maximum servomotor differential pressure of the turbine-control actuators, whichever is higher.
- c) Pump cycle time criteria. The pressure accumulator tanks system should be designed such that the minimum pump cycle time is greater than a specified value when the governor is controlling in steady-state operation. A value of at least 10 min is recommended. In no event should the number of pump starts per hour exceed the pump motor rating.

NOTE 1—Pump cycle times are generally a limiting factor with high-pressure systems, where the total control actuator volume is smaller, and the steady-state oil consumption is higher. Pump cycle times may also be a limiting factor with dual-regulated turbines, due to expected higher oil consumption rates resulting from the greater quantity of valves and the oil head leakage on adjustable-blade turbines.

NOTE 2—The pump cycle time criteria do not apply to an HPSS equipped with a continuously operating makeup (jockey) pump.

IEEE Std 1207 may be consulted for additional details.

5.4.10 Sump tank

The sump tank should be of cast or welded construction and provided with fine mesh screen strainers that are readily accessible for cleaning. The size of the mesh strainer should be specified. An oil level indicator should be incorporated into the design of the sump tank. The sump tank volume should not be less than 110% of the total volume of hydraulic fluid that can be returned to the sump tank by system pressure and by gravity. Necessary access doors should be provided for the purposes of cleaning and inspection. The sump tank should be designed to provide an adequately long return path of the hydraulic fluid from the control valve return to the pressure pump inlet to allow the release of entrained gas before reaching the pressure pump. This is particularly important in high-pressure systems (typically 2.5 MPa and above) using air-over-oil gas cushion in the pressure accumulator tank, where blackening of the hydraulic oil can occur as a result of compression-induced combustion of the oil with the entrained air.

5.4.11 Oil cleanliness control

The HPSS should include a system for continuously maintaining the cleanliness of the hydraulic fluid. A typical approach is to use a continuously running “kidney-loop” filtering system. Kidney-loop pumps are typically low pressure recirculating pumps. Alternatively, a high pressure makeup (jockey) pump may be used for continuous oil filtration purposes (for systems so equipped).

Indication, either a mechanical indicator or an electrical contact, should be provided to alert personnel when it is time to change the filtering element.

5.4.12 Oil temperature control

An oil temperature control system may be incorporated into the HPSS to maintain a minimum oil temperature which is typically the higher of 40 °C or 5 °C. above ambient. Oil heating provides benefits of minimizing sump condensation, providing consistent performance (for example, deadband, control actuator velocity limits) and enhancing trapped air (or gas) release. The latter is particularly important in high-pressure systems using air-over-oil gas cushion in the pressure accumulator tank, where blackening of the hydraulic oil can occur as a result of compression-induced combustion of the oil with the entrained air.

Either thermostatically-controlled electrical heaters or low-intensity heating by a continuously running pump discharging through a restriction may be used to accomplish the oil warming. If electrical heaters are specified, they should be a low intensity design to avoid hot spot induced oil blackening.

5.4.13 Automatic gas admission system

An automatic gas admission system may be specified to automatically maintain the proper fluid-to-gas ratio within a gas-over-oil type of pressure accumulator tank. The automatic gas admission system should be complete, with the necessary compressed gas supply system, piping, pressure sensors, and level sensors. Typically, either compressed air or compressed nitrogen is used to provide the gas-over-oil cushion within the pressure accumulator tank.

Typically, the automatic gas admission cycle should be initiated when the pressure accumulator oil level reaches a specified level above its normal level at the nominal system pressure. Proper interlocks should be provided to assure that the compressed gas supply pressure is sufficient to guarantee that gas will be admitted to, rather than drained from, the pressure accumulator tank. The automatic gas admission cycle should terminate when the relationship between the hydraulic pressure and the oil level in the pressure accumulator tank is within normal limits.

5.4.14 Piping and fittings

All piping and tubing should be suitable for use over a temperature range of -30 °C to +65 °C. Piping should conform to the edition in effect at the time of system specification of ANSI/ASME Std B31.1-1986 [B3], or other international standard. All joints should be of the bolted, flanged type. Threaded pipe should not be used in new installations due to concerns with oil leakage. Threaded pipe should be used only where necessary in governor replacement or conversion applications. Piping should be cleaned inside and out to remove mill scale. For adjustable-blade turbines, provision should be made to prevent the flow of electric currents within the piping to the runner blade control actuator.

Tubing should be hydraulic-line seamless tubing conforming to the edition in effect at the time of system specification of ANSI Std B93.11M-1981 [B4] or other international standard. Tubing fittings should be of a leak-resistant design suitable for an industrial environment. The following types of fittings have been used successfully:

- Flare-less sleeve fittings
- O-Ring face seal braze-on fittings
- 37° flare-less fittings

If required by the purchaser, piping and tubing joints should be certified by the authority of jurisdiction at the site of the installation.

Flexible hoses should be limited to locations where it is required for purposes of vibration isolation or to absorb component movement. Flexible hoses should be kept as short as practical. Instances where flexible hosing is acceptable include the following:

- Connections to the HPSS pumps
- Final connections to the actuator control actuators

The total pressure drop along the piping (or tubing) from the distributing valve to the turbine-control actuators and back should be no more than 8% of nominal system pressure with the control actuator traveling at its maximum velocity limits.

For adjustable-blade turbines, a bypass line may be installed across the blade control actuator open-and-close lines and as close as practical to the oil head. This may be required to prevent a vacuum being drawn into one of the lines when the servomotor is squeezed at either the fully open or fully closed position.

5.4.15 Filtration of trapped oil

In some cases, the volume of oil in the piping (or tubing) from the distributing valve to the turbine-control actuators and back may be greater than the combined volume of all turbine-control actuators. As a result, a portion of this oil will not return to the HPSS for filtration. The following methods may be used to overcome this problem:

- Locate the distributing valve as close as possible to the turbine-control actuators.
- Decrease the piping (or tubing) diameter, subject to the piping pressure drop criteria in 5.4.14.
- Install a bypass line, with orifice, between the control actuator open and close lines. The orifice size should allow a flow of one pipe volume every 20 min to 60 min, subject to the pump cycle time restrictions detailed in item c) of 5.4.9.
- Install a bypass line, with manually operated valve, between the control actuator open and close lines.
- Install a bypass line, with solenoid operated valve, between the control actuator open and close lines. The valve may be cycled by the controller using a low duty cycle.

5.5 New installation considerations

5.5.1 Hydraulic pressure supply system (HPSS)

For installations of new HPSSs for new turbine/generator installations, the manufacturer should coordinate the design of the HPSS with the design of the turbine and generator. Some key areas to address include the following:

- Nominal hydraulic supply pressure
- Turbine-control actuator dimensions
- Maximum loading of the turbine-control actuator
- Maximum rate of travel of the turbine-control actuator
- Adjustment range for rate of travel of the turbine-control actuator

5.5.2 Governor

For installations of new governor-control systems for new turbine/generator installations, the governor manufacturer should coordinate the design of the governor-control system with the design of the turbine and generator. Some key areas to address include the following:

- Rated turbine speed
- Method of speed sensing
- Method of overspeed detection
- Method of turbine-control actuator position sensing
- Rotating inertia of the turbine/generator combination
- Inertia of the water column, both upstream and downstream of the turbine

5.6 Replacement and conversion considerations

For existing turbine/generator installations, the purchaser may choose to replace the governor or implement a digital conversion. In addition, the HPSS may be replaced. Replacement or conversion decisions are typically based on the following considerations:

- Lack of spare parts
- Reduced maintenance associated with newer technology components
- Enhanced performance
- To take advantage of the economic or environmental benefits of a higher pressure system

IEEE Std 1147 may be consulted for additional details.

5.6.1 Hydraulic pressure supply system (HPSS)

For installations of new HPSSs for existing turbine/generator installations, some key areas to address include the following:

- Evaluation of the condition of the existing turbine-control actuators and piping
- Full-stroke dimension of all existing turbine-control actuators
- Diameter of all existing control actuator pistons and piston rods if control actuators are to be replaced
- Maximum loading of the turbine-control actuators (may require a differential pressure test)
- Evaluation of environmental considerations of the total volume of oil in the HPSS

5.6.2 Governor

For conversions or installations of new governor-control systems for existing turbine/generator installations, some key areas to address include the following:

- Evaluation of the condition of the existing HPSS
- Evaluation of the condition of the existing governor distributing valve
- Other items listed in 5.6.1

5.7 Redundancy

Critical turbine-generator units typically require a higher degree of component redundancy in order to achieve high unit availability or to ensure an automatic shutdown in the event of a component failure. Cases where this may be required are large turbine-generator units with a high commercial value, single unit plants, run-of-the-river plants, plants with environmental sensitivities, or plants with fishery considerations.

The amount of component redundancy should be specified. The following is a list of components that may be specified to be redundant:

- Power supplies
- Speed switches
- Overspeed switch
- Gate or deflector position switches
- Protection functions (for example, HPSS low pressure shutdown)
- Digital controller main processor module
- Digital controller input/output modules
- Sensors (for example, speed, pressure, control actuator position)
- Electro-hydraulic valves including shutdown valve
- HPSS pumps, motors, unloaders

5.8 Failsafe features

A variety of failsafe features should be specified. Some commonly specified features are detailed in 5.8.1, 5.8.2, 5.8.3, and 5.8.4.

5.8.1 Shutdown solenoid valve

A shutdown solenoid valve should be provided. When de-energized, the solenoid should hydraulically force all control actuators to their failsafe position, irrespective of the governor controller's electrical command signals. Typically, the design will force control actuator closure when the solenoid is electrically de-energized. The shutdown solenoid should be powered from an uninterruptible source (battery backed dc or ac).

5.8.2 Actuator lock

An automatic locking feature may be provided to freeze the turbine-control actuator in its last position upon failure of certain control signals, such as speed sensing or power sensing. This locking feature should allow closure of the turbine-control actuator via a normal or protective shutdown of the turbine-generator unit.

5.8.3 Open circuit detection

An alarm may be raised in the event of an open circuit condition on any analog input, any analog output, or both. The alarm should clearly identify exactly which input or output is open circuited. A shutdown may be generated for inputs or outputs deemed to be critical.

5.8.4 Power transducer failure

Failure of the power transducer, for governors so equipped, should transfer the governor to position control mode. An alarm should be raised. See Annex C for a typical logic implementation.

5.9 Dual-regulated turbines

Dual-regulated turbines include adjustable-blade turbines and impulse turbines.

5.9.1 Adjustable-blade turbines

Adjustable-blade turbines include separate control actuators to control both the wicket gates and the runner blades. Governor-control systems for adjustable-blade turbines include two governor-control valves, one for the wicket gate control actuator control and one for the runner blade control actuator control.

5.9.1.1 Blade control

In order to achieve maximum operating efficiency of an adjustable-blade turbine, along with minimum cavitation damage and possibly maximum fish survivability, the runner blade angle should be positioned as a three-dimensional function of the wicket gate position and the operating head of the turbine. The governor manufacturer should make provisions for updating this blade control relationship based upon subsequent index testing of the turbine. The governor controller should maintain the steady-state blade position within 1% of the computed optimal blade position under any operating conditions.

For turbines that experience unusually large hydraulic instabilities, it may be necessary to specify an intentional delay time (fixed or variable) in the blade control strategy to suppress undesirable blade movement. Details of the strategy should be specified.

5.9.1.2 Blade locking

The specifier may require a blade locking function to prevent further movement of the blade control actuator under specified operating conditions. This locking feature may either be implemented within the governor controller by freezing the blade control actuator position set point, or it may be implemented using automatic isolating valves in the blade control actuator hydraulic-control piping. Some typical conditions that activate a blade locking feature include the following:

- Low hydraulic supply pressure
- Blade position switch operation
- High or low turbine operating head
- Excessive oil head leakage detected

5.9.1.3 Blade tilt

The specifier may require a blade tilt function to tilt the runner blades to a specified adjustable position under specified operating conditions. A typical application tilts the runner blades to their maximum steep position (i.e., parallel to the water flow) when a specified overspeed condition is experienced. Tilting the blades in this manner more rapidly returns the turbine to its normal operating speed. The runner blades should be returned to their normal operating position at or above the normal rated speed of the turbine.

5.9.1.4 Manual blade control

The specifier may require the capability of manually setting the runner blade position, independently from the wicket gate position or the operating head level.

5.9.2 Impulse turbines

Impulse turbines incorporate one or more flow-control nozzle control actuators, along with a deflector-control actuator to achieve rapid reduction in power developed by the turbine when required. Governor-control systems for impulse turbines include a control valve for the deflector-control actuator control and a control valve for each flow-controlling nozzle.

Typically, the timing of the flow-controlling nozzles is too slow to achieve acceptable unloading rates under time-critical operating conditions.

Multiple modes of operation are achievable with an impulse turbine equipped with deflectors, including “water-saving” and “water-wasting” modes of operation. The governor-controller strategy should provide separate damping adjustments to accommodate the active mode of operation. Additionally, a nozzle-sequencing mode of operation may be specified.

5.9.2.1 Water-saving operation

The water-saving mode of operation describes the operation of an impulse turbine when the deflectors are out of the water stream under steady-state conditions, thus no water is “wasted” by being deflected away from the turbine runner. The water-saving mode of operation is typically used when the generator is grid-connected. The governor manufacturer should provide a tunable relationship between the flow-controlling nozzle position and the deflector position. The purpose of this tunable relationship is to position the deflectors just outside the water stream during steady-state conditions to minimize the travel time required to bring the deflectors into the water stream during transient conditions. Under water-saving operation, only the flow-controlling nozzles will have an effect upon the operation of the turbine (except during overspeed conditions when the deflectors move into the stream).

5.9.2.2 Water-wasting operation

The water-wasting mode of operation describes the operation of an impulse turbine when the deflectors are continuously in the water stream, deflecting part of the water flow away from the turbine runner. The

water-wasting mode of operation is typically used either to limit the speed of the turbine following a load rejection, or to achieve better frequency stability when operating isolated from an interconnected power system. It can also be used for improved frequency control following cold load pick-up if operating isolated. The amount of load that can be accommodated without an unacceptably large deviation in generator frequency is determined by how much water the deflectors are diverting away from the turbine runner. Under water-wasting operation, the controlling action of the deflectors is dominant, and the controlling action of the flow-controlling nozzles is generally insignificant.

5.9.2.3 Nozzle-sequencing operation

The efficiency of a multiple-nozzle impulse turbine is affected both by its generation level and by the number of flow-controlling nozzles in service. In certain applications, the efficiency of a multiple-nozzle impulse turbine can be improved by closing one or more flow-controlling nozzles during low-power operation. The radial balancing of the water forces upon the turbine guide bearings should be considered if a nozzle-sequencing operation is specified. The deflector positioning algorithm should be coordinated with the number of nozzles in service. The transition between different numbers of nozzles in service should be designed to minimize transients in speed and generation.

During nozzle sequencing operation, the radial balancing forces should be continuously calculated based upon the positions of all “in service” nozzles. An alarm should be generated if the radial forces become unbalanced for a user adjustable time period. In addition, a trip may be specified if the radial forces become unbalanced for a user adjustable time period.

5.10 Additional governor-controller functions

The functions described in 5.10.1, 5.10.2, 5.10.3, and 5.10.4 were historically provided by hardware external to the governing system. The flexibility and power of modern digital controls has opened the possibility of integrating these functions into digital controller based speed-governing systems. Which functions to integrate will depend upon the user’s operating and maintenance practices as well as design philosophy. Careful consideration should be given to failure modes and effects prior to deciding which functions to integrate. The following clauses apply primarily only to digital controller based governors.

5.10.1 Starting and stopping control of turbine-generator auxiliaries

The specifier may require that starting and stopping of turbine-generator (unit) auxiliaries be under the control of the governor controller. The sequence of auxiliary device starting and stopping should be specified. A set of pre-start permissives should be satisfied in order for the operator initiated start-up command to allow auxiliary device start-up. Each step of the start sequence should be interlocked with the preceding step. In other words, if a particular step did not successfully complete (for example, an auxiliary pump fails to start), then the succeeding step should be blocked from starting. Details of the pre-start permissives and the sequence interlocks should be specified.

In the event that all auxiliaries do not successfully start within a pre-determined time interval, an alarm should be raised and an orderly shutdown of auxiliaries should be initiated.

Adoption of this additional feature results in significant increases in the input/output hardware and governor-controller software requirements with subsequent increases in cost and complexity.

In the event of a governor controller failure, it should be possible for the turbine-generator to be shut down safely by the automatic protection system (supplied by others). Sufficient hardwired circuitry external to the governor controller should be provided to meet this failsafe requirement.

For further details of unit auxiliary start/stop controls, see IEEE Std 1249™-1996 [B21] and IEEE Std 1010.

5.10.2 Draft tube air depression control

Reaction turbines designed to operate in synchronous condenser mode may be equipped with draft tube air depression capability. The specifier may require control of the air depression equipment (for example, air valve or valves, blower, cooling water valve, etc.) via the governor controller.

The air depression control sequence should be specified in detail by the specifier. For further details on air depression controls, see IEEE Std 1010.

5.10.3 Hydraulic pressure supply system (HPSS) control

Specifiers may wish to embed the HPSS pressure pump or gas admission control logic into the governor controller. Control of the lead and lag pressure pumps should function as described in 5.4.3. Control of the automatic gas admission device should function as described in 5.4.13.

5.10.4 Turbine pressure regulator valves and bypass valves

If the turbine is equipped with a pressure limiting device, such as a pressure relief valve (PRV), synchronous bypass valve (SBPV), or similar equipment, the control of these devices may be integrated into the governor controller. The purpose of the pressure limiting device is to maintain the penstock water pressure within acceptable upper and lower limits. A PRV is typically operated as a defined function of the penstock pressure. An SBPV is typically operated as a defined function of primary turbine flow control device (for example reaction turbine wicket gates) position and velocity. The desired functionality and failsafe design features of the pressure-limiting device should be fully specified.

To protect the penstock from excessive positive or negative pressures, it is important to ensure that the PRV (or BPV) position stays synchronized with the primary turbine flow control device. An independent method of detecting loss of synchronization or penstock pressure or vacuum limits violated may be used to initiate appropriate failsafe protective action. Typical actions include restricting the wicket gate and PRV (or BPV) control actuator velocities to safe values (for example, activating throttle valves or restricting distributing valve spool movement) and hydraulically forcing the control actuators to their failsafe positions.

During reaction turbine overspeed conditions (for example, load rejection), the flow of water into the turbine may be reduced as a result of the throttling effect of the turbine blades which are moving at abnormally high velocity. This throttling effect should be taken into consideration when developing a strategy for the synchronization of the wicket gates and PRV (or BPV).

5.11 Environmental specifications

5.11.1 Temperature

All solid-state devices and components should be rated for industrial or military grade duty, suitable for operation at temperatures between 0 °C and 55 °C.

5.11.2 Transient immunity

The governor-control system should be immune from false operation or failure from high voltage, high frequency transients that may be introduced into the control circuitry and power supplies both internal to and external from the governor-control system. To reduce the introduction of transient noise into the governor control circuitry, the governor manufacturer should use properly shielded cable for connection to external equipment, should use optically- or transformer-isolated amplifiers for signals to and from the governor-control circuitry, and should assure that properly-rated surge suppression devices are installed on all inductive devices connected to, or in proximity to, the governor-control equipment. The governor-control system should be designed and tested for surge withstand capability in accordance with IEEE or IEC standards such as IEEE Std C37.90.1™-2002 [B22], IEC 60255-22-1 Ed. 2.0b (2005-03) [B10], IEC 60255-22-4 Ed. 2.0b (2002-04) [B11], IEC 60255-22-5 Ed. 1.0b [B12].

The governor-control equipment should be designed and tested to be insensitive to radiated high frequency interference such as that coupled from portable radio transmitters. A field strength withstand level may be specified for the governing system. Typical values range from 10 V/m to 20 V/m over the frequency range of 25 MHz to 1000 MHz. As a minimum, tests should be conducted at 150 MHz band, 400 MHz band, and in some countries, 900 MHz band. Alternatively, the power rating and frequency of the purchaser's transceivers and the desired minimum operating distance between transceiver and governor equipment location may be specified.

See also IEEE Std 1207 for other references on electromagnetic interference.

5.11.3 Seismic

Seismic design requirements may be specified. If seismic requirements are necessary, they should be considered on a plant-specific basis. The seismic requirements should either be referenced or included in the governor specification.

5.12 Software

Where a digital governor controller is supplied, a complete set of program and data base files and software configuration and programming tools should be provided for all digital devices installed in the system. As a minimum, the following should be provided:

- The source code, program or function file that defines the control sequence/strategy for a specific installation.
- The configuration programming software tool that is used to create and modify the source code and executable code.
- Any utilities required for uploading and downloading of the executable code and setting parameters.
- Any utilities required for viewing and modifying the setting parameters with the turbine either running or stopped.
- Any utilities required for viewing of real time variables.

The following utilities are considered optional:

- Real-time trending tool
- Event-logging software
- Any utilities required for comparing the software residing in the programming computer with the software residing in the governor controller.

All source code should be identified with the revision date, revision number, and appropriate revision notes. All source code should be extensively documented.

There should be adequate access security (for example, password) for the following operations:

- Uploading and downloading of all software.
- Modifying all settings.

The executable code should reside in non-volatile memory to prevent loss of function in the event of governor controller power loss.

Software upgrades and technical support may be specified based on the purchaser's requirements.

The governor controller should have provisions to execute time critical functions at a guaranteed rate. A periodic execution schedule of at least once every 10 ms is typically specified. The areas of code that are considered time critical should be specified.

A warning mechanism should be provided when the size of the executable file has reached the limit of the governor controller's memory capacity or processing capacity.

5.13 Interface to other plant systems

The interface requirements to other plant systems which are remote from the governor should be specified. These systems may include:

- Unit controller
- Plant controller
- Central control room console
- Plant monitoring system
- Remote terminal unit for off site control

The interface to these systems should be specified as either communication interfaces or discrete hardwired interfaces. Discrete interfaces are required when interfacing a new governor to a system without communications capabilities. Discrete interfaces offer advantages of greater security and a more deterministic response under heavy data traffic conditions.

If a communications interface is specified, the physical layer and protocol requirements should be specified. If a discrete interface is specified, the specific requirements should be detailed (for example, raise and lower relay contacts, analog voltage set point).

The type and scaling of all signals provided for remote indication should be specified (for example, voltage, current, bipolar, uni-polar, range and scaling).

A list of quantities required for remote control purposes should be specified. Typical quantities are shown in Annex D, Table D.1.

For further details on interfaces to other plant automation systems, see IEEE Std 1010 and IEEE Std 1249-1996 [B21].

5.14 Operator interface

Details of the local operator interfaces should be specified including any preferences for either conventional controls and indicators or a digital operator interface terminal (OIT). Conventional controls typically include pushbuttons or switches. Conventional indicators typically include discrete meters and either lamp or LED indicators.

Quantities required for local control purposes should be specified. Typical quantities are shown in Annex D, Table D.1. All critical controls should be conventional hardwired controls.

Where an OIT is supplied, it should be powered by an uninterruptible source (battery-backed dc or ac). The OIT should have the following user specified minimum capabilities:

- Number of lines of alphanumeric text on each screen or page.
- Number of characters of alphanumeric text on each line.
- Number of separate screens or pages.

A detailed list of alarms may be specified. Annex D, Table D.1, provides a typical list. Digital governors typically have a much greater quantity of alarms in comparison to older governors. This is efficiently handled with a communicated interface to other plant systems. If a discrete alarm interface to other systems is required (for example, alarm contacts for connection to a remote alarm annunciator), the specifier may require alarm grouping. A typical scheme is to group alarms into categories of urgent, semi-urgent and non-urgent.

5.15 Personnel safety features

Subclauses 5.15.1 through 5.15.5 include safety features that are typically included in speed-governing systems. It is by no means an exhaustive and comprehensive list of safety features. It should not be considered to be an authoritative treatment of safety features, nor a substitute for national, state, provincial, regional or corporate safety codes.

5.15.1 System grounding

The Governor cabinet and HPSS should be designed for grounding to the station ground mat. Two parallel ground connections may be specified for the HPSS for added security due to higher available ground fault levels. All equipment in the governor should be electrically bonded to the cabinet or frame ground.

For electrical noise suppression purposes, a common practice is to create a separate electronic circuit ground bus, which is connected to the cabinet at a single point. In some cases, further improvements in regard to noise suppression may be obtained by isolating the cabinet ground from the electronic ground. If isolation is deemed necessary, care should be taken to avoid violating electrical safety requirements. The expected ground potential rise under ground fault conditions should be accounted for when specifying the isolation scheme or method.

Adjustable-blade hydraulic oil piping should have electrical isolation at the oil head to prevent circulating currents through the generator shaft. Speed measuring equipment should be electrically isolated from the generator shaft.

See IEEE Std 1010 and IEEE Std 665TM-1995 [B18] for further details on grounding.

5.15.2 Automatic gate actuator lock

An automatic wicket gate servomotor lock (gate lock) may be specified as part of the turbine-control actuator. The lock may incorporate an automatically controlled valve to operate the locking device when the wicket gates reach the fully closed position during a turbine shutdown. The purpose of the automatic lock is to prevent an inadvertent turbine rotation if the HPSS hydraulic pressure is lost. If the lock also serves as a personnel safety feature while the hydraulic system is charged, the lock should be designed to withstand full hydraulic pressure. Limit switches to indicate the position of the control actuator locking device may also be specified. A gate lock “fail to apply” alarm may also be specified.

Nozzle control actuator locks are not generally specified unless there is a possibility of the nozzles opening due to the influence of penstock pressure.

5.15.3 Manual control actuator lock

A manual wicket gate servomotor locking facility may be specified. This may be required where an automatic locking facility is not supplied, where the automatic facility is incapable of withstanding full hydraulic pressure or where the automatic facility is not considered to be sufficiently safe and secure. The manual control actuator lock should lock the gates in the fully closed position. In some instances, locking the gates in a partially open or fully open position may be specified. For impulse turbines, manual control actuator locks may also be specified for deflector or nozzle control actuators.

5.15.4 Hydraulic isolation valves

Hydraulic isolation valves may be specified to be installed on appropriate hydraulic lines. Bleed valves may also be specified for installation on the safe (non-source) side of the isolation valves for purposes of returning oil to the sump. The quantity and location of these valves should be specified. Valve locking provisions may also be specified.

5.15.5 Electrical safety switches

Safety isolation switches may be specified to be installed at appropriate locations such as on the pump motors. The quantity and location of these switches should be specified. Switch locking provisions may also be specified.

5.16 Spare parts and accessories

The manufacturer of the governor-control system should provide a list of recommended spare parts, along with a list of any special tools or accessories necessary for the operation and maintenance of the system being provided.

5.17 Product support

Recent experience has shown that the service life for some digital governors is relatively short compared to historical experience. Users may wish to take the following precautions to mitigate the problems of early product obsolescence:

- Purchase two or more spares for each part
- Avoid the purchase of technology that is in the late stages of its life cycle
- Avoid the purchase of technology that is considered at risk of failing to gain wide market acceptance
- Guarantees of product support from the manufacturer
- Specify the use of standard interface signals and protocols
- Specify the use of widely available components and avoid the use of “tailor made” solutions
- Ensure adequate product documentation is supplied in case the manufacturer ceases to support the product

6. Performance specification

6.1 Stability

The governor system should be capable of controlling, in a stable manner, the speed and power of the turbine at all power outputs between zero and maximum power output inclusive. This applies when the generating unit is operating isolated, or when the generating unit is operating in parallel with a large interconnected power unit.

The range of conditions covered by stability requirements includes sustained conditions, load rejection, and sudden changes of isolated load, both large and small.

6.1.1 Sustained conditions

Steady-state stability indices may be specified. If specified, the purchaser should recognize that persistent oscillatory mechanical power surging may occur as a natural result of the water passage or turbine design. This natural surging must be accounted for when determining the governor’s ability to maintain steady-state stability.

- a) The steady-state governing speed band (also called speed stability index) under either speed-no-load or loaded conditions should be no more than 0.1% with the generator off-line and operating at 5% speed droop (position, power, or flow).
- b) The steady-state governing load band (also called power stability index) should be no more than 0.4 % with the turbine-generator unit operating at 5% speed droop (position, power, or flow) and operating outside of the turbine rough zone.

NOTE—Some digital governors are capable of damping out any turbine-induced natural power surging. This damping may come at the expense of excessive wear on the governor, control actuator, or turbine-control device. If this occurs, the steady-state governing speed band may be increased; however, it should not exceed 0.3%.

6.1.2 Load rejection

Following rejection to zero of any load within the capability of the governed turbine, speed should be returned to the speed reference as may be modified by speed droop (position, power, or flow), with no more than one under-speed deviation not to exceed 5% and one overspeed deviation not to exceed 5% subsequent to the initial overspeed deviation. This specification presumes that the turbine-control actuator cushion retards control actuator movement only in the closing direction and at control actuator positions less than speed-no-load.

NOTE—Retardation by the turbine-control actuator cushion system of control actuator movement in the opening direction may degrade recovery of speed control following rejection to zero load. Inclusion of this paragraph will require turbine model data and may require additional hardware.

6.1.3 Speed control, fluctuating isolated load basis

This requirement pertains to the suitability of the principal damping elements of hydraulic turbine governors. Performance for this isolated load condition is separately specified, since adequacy of the damping system for this condition is not ordinarily revealed by performance under grid-connected conditions or by the no-load condition following load rejection.

6.1.3.1 Damping capability

The range and effectiveness of the damping elements of the governor should be capable of providing suitably damped control of speed when the turbine-generator unit serves an isolated resistive load. Suitably damped control of speed should be demonstrated while the turbine-generator unit is carrying an isolated resistive load of approximately 90% of rating. The hydraulic head should be within plus or minus 10% of rating for this demonstration.

Suitability of damping of the speed deviations in the time domain should be shown following a sudden load change (increase or decrease) of not more than 5% of rating. Suitably damped control will be shown by attenuation of the second speed deviation of the same sign as the first deviation to not more than 25% of the first deviation.

In the frequency domain, the suitability of damping should be shown by a frequency response test performed at the operating point detailed above with signal levels within the linear response range of the governing system. The frequency response of interest is the open-loop response from the turbine shaft speed input to the governor to turbine shaft speed. This can best be obtained by cascading the frequency response taken from the governor shaft speed input to gate position, with the response taken from gate position to shaft speed under isolated conditions. Suitably damped control will be shown by an appropriate phase margin at unity gain crossover and an appropriate gain margin. Refer to IEEE Std 1207 for phase and gain margin guidelines.

NOTE 1—An open-loop criteria is considered to be a necessary condition for stability. Experience has shown it may not be a sufficient condition in all cases. Both an open-loop and a closed-loop stability criteria may be specified.

NOTE 2—The control of a resistive load is the historical standard of performance capability. It represents the strongest dependence upon the governor damping system likely to be needed in normal service. Evaluation may be achieved by tests, by computation, or by a combination of tests and computation as may be agreed upon between the purchaser and manufacturer.

6.1.3.2 Damping for non-resistive load

If the user's load conditions are known to differ from characteristics of the resistive load, the evaluation of adequacy of damping may be based upon such load characteristics by mutual agreement between the purchaser and the manufacturer. For this condition the purchaser should specify the inertia of the load and its load regulation characteristic (ordinarily the voltage will be maintained constant by the voltage regulator, and voltage dependency of the load need not be considered). The same degree of damping for the specified load should be achieved as for the reference resistive load.

6.1.4 Stability studies

As a result of the complex interrelated effects between the penstock, generator, turbine, governor, and power system, it may be desirable that a mathematical simulation of the entire system be performed. This is of particular importance if a large percentage of the system generation is supplied from one turbine-generator unit or if the physical characteristics of any parts of the system raise concern. The following text may be added to the procurement specification if a simulation study is required to be performed by the governor supplier:

The supplier should simulate, using appropriate methods, the interaction of penstock, turbine, generator, load, and governor in order to prove that the system is stable under all load conditions when adequate adjustments of the governor parameters are set and the pressure and transient speeds after load rejection are within the specified limits when the gate closing time is appropriately adjusted. The stability studies should cover the operating range between maximum and minimum net heads with the discharge corresponding to the full load under each respective net head. Studies should be conducted for conditions including parallel operation with an infinite system, supply of an isolated resistive load, and supply of isolated loads with special speed regulation characteristics specified. The studies should indicate the setting range of the governor parameters for which the control circuit remains stable after any disturbance. The quality of regulation should be demonstrated in diagrams indicating the transient response of the frequency of the isolated system to load variations (increase and decrease) for various net heads and the transient response of power for changes of the speed or generation reference when supplying an infinite system.

6.2 Permanent speed droop

The permanent speed droop (position, power, or flow) should be capable of adjustment to values between 0 and 10%. The speed-versus-feedback parameter (position, power, or flow) curve should be substantially linear over the full range of the feedback parameter; that is, the change in speed should be substantially the same for equal increments of the feedback parameter.

6.3 Deadband

The speed deadband at rated speed should not exceed 0.02% of rated speed at any gate setting.

For adjustable-blade turbines, the blade control deadband should not exceed 1.0%.

6.4 Deadtime

IEEE Std 1207 defines governor deadtime as the elapsed time between a change in speed and the first corrective action. The intended corrective action and the maximum allowable deadtime should be specified. Typically, the specified corrective action is the onset of movement of the primary speed regulating turbine-control actuator (wicket gate actuators for reaction turbines or deflector actuators for impulse turbines). For both wicket gates and deflectors, a maximum value of 0.2 s for a speed change of 0.1 Hz or larger is typical.

For impulse turbines, the deadtime associated with nozzle servomotors may be specified if it is deemed to be necessary. In many cases, it is not specified or measured since it does not typically have an impact on speed control. For adjustable-blade turbines, the blade deadtime should be specified. The blade deadtime is defined as the elapsed time from a required change in blade position until the onset of blade movement. This definition allows for the inclusion of intentional blade delays such as described in 5.9.1.1.

A maximum blade deadtime of 0.5 s is recommended. A lesser value may be required for turbines equipped with fast acting blades (for example, blade control actuator time of less than approximately 30 s).

For governor conversions, the total deadtime should be specified in a manner which includes the cumulative delay effects of only those components to be supplied by the manufacturer.

6.5 Governor damping adjustments

The various damping parameters should be provided with the following range of adjustment for temporary droop, PID, and double-derivative type strategies. Separate sets of damping parameters should be provided for on line and off line conditions. A third set of damping parameters may be specified for isolated or islanded operation.

6.5.1 Temporary speed droop adjustments

The decay time constant of the damping system should be continuously adjustable from 0 to 30 s. The temporary speed droop should be continuously adjustable from 0 to 150%.

6.5.2 Proportional, integral, and derivative (PID) adjustments

The proportional gain should be continuously adjustable from 0 to 20. The derivative gain should be continuously adjustable from 0 to 5 s. The integral gain should be continuously adjustable from 0 to 10 per second. The proportional, integral, and derivative gains are defined from governor speed input to governor system output.

6.5.3 Double derivative or lead-lag adjustments

The lead and lag time constants should have a continuously adjustable range from 0.01 to 10 s. The derivative gains should be continuously adjustable from 0 to 10 s.

7. Information provided by the manufacturer

7.1 Information to be provided at the time of submission of proposals

7.1.1 Technical submissions

The manufacturer should furnish diagrams or drawings of the speed-governing system together with a written description clearly explaining the principle of operation. This information should include outline drawings showing major dimensions and appropriate mathematical models for use in dynamic computer studies.

7.1.2 Long-term maintenance

The manufacturer should provide documented assurance that the equipment will be supported by the manufacturer for a specified time period. A time period of 20 years to 40 years is typical. This support should include the availability of proprietary spare parts, availability of software, troubleshooting support, and resolving any design flaws. The purchaser may require the manufacturer to hold in escrow certain proprietary information such as software source code and drawings.

7.2 Information to be provided after contract award

The following are suggested as reasonable requirements for furnishing of drawings and materials by the manufacturer. The specification writer should modify the requirements to suit his particular needs, including the times allowed for submission.

7.2.1 Drawings and software

After contract award, the manufacturer should submit drawings and software to the purchaser in a specified time frame for approval or usage as follows. CAD drawing files may also be supplied.

- General arrangement drawings showing confirmed overall dimensions and weights of the principal parts of the governor, sufficient to allow concrete foundation work in the powerhouse to proceed.
- Drawings showing full details of foundation requirements, required erection procedures, required erection provisions, hydraulic schematics, functional descriptions, and electrical schematic diagrams for all parts of the governor system, including all necessary components and auxiliary devices to make a complete system.
- Application software source code listing (if required) and wiring drawings.
- At the completion of commissioning, all software as defined in 5.12 and all final drawings. Purchasers may also require drawings and software after the completion of the factory test.

7.2.2 Installation instructions

The manufacturer should provide installation instruction describing in detail the recommended procedure for installing the governor and all its components. The instructions should include procedures for on-site acceptance and inspections.

7.2.3 Operation and maintenance manuals

The manufacturer should provide operation and maintenance manuals describing in detail the recommended procedure for assembling, dismantling, maintaining, troubleshooting, and operating the governor and all its components.

Without restricting the generality of the foregoing, the manuals should include at least the following:

- Technical and design data including weights of all major components.
- All pertinent bulletins and instruction manuals prepared by the various manufacturers of component parts of the governor. Manufacturers' bulletins should be suitably annotated to clearly indicate those items that form a part of the complete assembly.
- Procedures for assembling, dismantling, operating, diagnosing trouble, and maintaining the governor.
- Procedures and technical data required to properly adjust the governor.
- Lubrication requirements, including a list of recommended lubricants for all components of the governor.
- A complete index of all the contractor's drawings and a list of all assembly bulletins and drawings prepared by the manufacturers of components of the governor.
- A selected set of arrangement, schematic, and wiring drawings for the governor, reduced in size to suit the instruction manuals.
- A set of assembly drawings or printed bulletins that show all individual components of the equipment and that indicate and identify each component item number, including the common commercial designation.
- Instructions on the use of all software tools including procedures for uploading and downloading of executable code or settings and for modifying the executable code.
- List of recommended spare parts and consumables.

The specified number of copies of the manual should be submitted in draft form to the purchaser for approval prior to delivery. Following approval by the purchaser, the specified number of suitably bound copies and one copy of the electronic file in non-volatile media (file format and media to be specified) of the manual should be supplied.

Should the manufacturer find it appropriate or necessary thereafter to amend such instruction manuals, he should, after obtaining purchaser's approval, promptly provide the specified number of any such amendments plus an updated electronic file.

7.3 Test procedures

Test procedures for factory acceptance testing and site acceptance testing should be provided by the manufacturer for approval. The factory test procedure should indicate which steps of the factory acceptance testing are for customer witnessing. The site acceptance test procedures should be written in accordance with the purchaser's local safety rules and procedures.

The following test and inspection reports should be provided by the manufacturer after test completion:

- Factory acceptance tests
- Commissioning tests
- Site acceptance tests

7.4 Rehabilitation and conversion considerations

Particular attention should be paid to the mechanical interface between existing equipment and new equipment. Dimensional information shown on existing plant equipment drawings should be confirmed or updated by the manufacturer. This may require a visit to the site by the manufacturer. Dimensional drawings showing details of the interface between existing equipment and new equipment should be provided no later than two months after contract award.

8. Governor testing

Governor performance tests are typically required to demonstrate that the governor system meets the specified performance criteria. Some tests are typically performed at the governor equipment manufacturer's factory, and certain tests are typically performed on-site after installation of the equipment.

Suggested target values for some performance criteria are provided below or in some cases in Clause 5 and Clause 6 of this recommended practice. These target values may be pre-empted by system operator requirements.

Further details regarding some of the tests described below are provided in standard IEEE Std 1207.

The tests listed below do not comprise an exhaustive set of tests. For more complete testing requirements, references ANSI/ASME Std PTC29-1965 [B1] and IEC 60308 (1970-01) [B13] should be consulted.

8.1 Factory acceptance testing

Certain tests should be performed at the governor manufacturer's factory to demonstrate that the governor equipment complies with the specified governor performance parameters. The specifier of the governor equipment may require additional factory tests to be performed.

8.1.1 Speed and blade deadband test

The manufacturer of the governor equipment should demonstrate that the governor is capable of meeting the required speed deadband and, if applicable, the required blade deadband.

8.1.2 Deadtime test

If the control actuator control valve is part of the governor-control system being provided, the governor manufacturer should demonstrate that the governor is capable of providing a movement of the main speed regulating turbine-control actuator (wicket gate or deflector) within a specified deadtime after a turbine speed change, such as would be experienced after a sudden load change of 10% or more of the turbine-generator unit's rated generation while operating isolated from an interconnected power system.

If the control actuator control valve is not part of the governor-control system being provided, the governor manufacturer should demonstrate the deadtime of only those components to be supplied.

For adjustable-blade turbines, the blade deadtime should also be demonstrated. This may be achieved by using a recording device which plots both blade setpoint and blade position during an event which causes a sudden change in blade set point.

For impulse turbines, the nozzle deadtime may be demonstrated if desired.

8.1.3 Speed droop test

The manufacturer of the governor equipment should demonstrate that the governor responds to changes in simulated turbine speed according to the specified permanent speed droop characteristic for the governor.

8.1.4 Damping verification test

The manufacturer of the governor equipment should demonstrate that the range of adjustment of the damping system gains and time constants meet the purchaser's specifications.

8.1.5 Start/stop sequence test

The manufacturer of the governor equipment should demonstrate that the governor responds in the specified manner to start and stop commands. The functionality of all other remote and local controls should also be demonstrated.

8.1.6 Model verification test

If required by the purchaser, the system frequency response, time response, or both, may be tested to demonstrate that the governor-control system responds in a manner consistent with the specified mathematical governor-control system model.

8.1.7 Transient immunity test

If required by the purchaser, the manufacturer may conduct radio frequency interference (RFI) tests or surge-withstand capability tests on the governing system equipment. IEEE Std C37.90.1™-2002 [B22] is commonly specified for surge withstand testing.

8.1.8 Accuracy tests

If required by the purchaser, the manufacturer may conduct accuracy tests on specified analog inputs such as control actuator position feedback, speed feedback or active power feedback. If supplied by the manufacturer, the associated sensors and transducers may also be tested for accuracy.

8.2 On-site acceptance testing

Certain tests should be performed at the installation site to demonstrate that the governor equipment complies with the specified governor performance parameters. The specifier of the governor equipment

may require additional on-site tests to be performed depending on past experience or to meet regulatory requirements.

8.2.1 Control actuator timing test

The installation supervisor on-site should demonstrate that the maximum-rate timing of the turbine-control actuators complies with the specified timing, within specified tolerances. Typically, this control actuator timing is initially demonstrated with the turbine dewatered, and repeated with the turbine watered up. Required adjustments should be made so the turbine-control actuator timing complies with the governor system specifications with the turbine watered up.

The purchaser may specify that timing tests be performed at both nominal and minimum HPSS pressure. The tests should be performed over the full range of actuator positions to verify cushioning requirements (for actuators so equipped).

8.2.2 Governor speed control damping test

The damping of the governor control of turbine speed should be demonstrated at-site by inducing a disturbance, while operating isolated from the interconnected power system, and recording the gate position and speed while recovering from the induced disturbance. The induced disturbance may be implemented by applying the gate limit to reduce the operating speed of the turbine, and suddenly raising the gate limit out of the way, by connecting or disconnecting an isolated load from the generator or by injecting a speed signal small step change.

8.2.3 Deadtime tests

The governor deadtime may be measured by rejecting a load of at least 10% of the rated generation of the turbine-generator unit, and measuring the elapsed time between the opening of the unit breaker and the first movement of the main speed regulating turbine-control actuator. For adjustable-blade turbines, the blade deadtime may be measured using a method similar to that specified in 8.1.2.

For impulse turbines, the nozzle deadtime may be demonstrated if desired.

8.2.4 Load rejection test

The governor response to a load rejection may be demonstrated by recording the actuator position and the turbine-generator unit speed in response to tripping the unit breaker at various specified loads, typically 25%, 50%, 75%, and 100% of the rated generation. The maximum overspeed experienced at each level of load rejection is determined by the deadtime of the governing system and the rate of closure of the actuator. The number and magnitude of speed deviations after the initial overspeed transient is an indication of the governor control damping.

8.2.5 Steady state stability tests

A speed stability index test and a power stability index test may be specified. If such tests are specified, the limitations detailed in 6.1.1 should be recognized.

8.2.6 Other control tests

8.2.6.1 Speed reference range test

The speed reference range adjustment specified in 5.2.4 should be demonstrated.

8.2.6.2 Gate limit control test

The controller actuator limit specified in 5.2.5 should be demonstrated.

8.2.6.3 Manual control test

The manual control functionality specified in 5.2.9 should be demonstrated.

8.2.7 Online set-point response test

The response to a set-point change may be demonstrated by changing the governor set point with the unit operating online while recording key variables such as active power and control actuator position. The specifier may require that tests be performed with the governor operating in more than one mode of operation.

8.2.8 Online simulated speed step test

The response to a simulated speed step change may be demonstrated by creating a simulated speed step change and recording the control actuator time response. The results may be used to judge the overall governing system response and to verify governor model parameters.

8.2.9 Model verification test

The model verification testing described in 8.1.6 may also be done as an on-site test. For online tests, the impact upon the interconnected grid should be taken into consideration. The model verification testing may be required to meet regulatory requirements. For further details, refer to IEEE Std 1207.

8.2.10 Communication tests

Where communication between the governor and other devices is specified, the complete functionality of the communications interface should be demonstrated by sending and receiving data between devices.

9. Information provided by the specifier

The following list of information is based on the assumption that control actuators are to be provided by others or already exist.

- Rated turbine output.
- Net head (including variations).

- Rated speed.
- Rated discharge.
- Type or types of set parameter(s) (set-point references).
- Ambient conditions.
- Seismic requirements.
- Surge tank dimensions and type.
- Water inertia time (penstock, spiral case, and draft tube).
- Relief valve capacity under full head.
- Turbine-generator unit mechanical inertia.
- Station service ac and dc voltages including ranges of variation, for governor-control and power circuits.
- Powerhouse drawings showing suggested location of equipment.
- Combined gate control actuator volume and stroke.
- Deflector-control actuator volume and stroke.
- Nozzle control actuator volume and stroke, when governor-operated.
- Runner blade control actuator volume and stroke.
- Control actuator design (nominal) operating pressure.
- Turbine-control actuator connection sizes.
- Control actuator travel direction to close.
- Minimum differential pressure required to move control actuators.
- Maximum pressure control actuators are capable of withstanding.
- Gate shaft or deflector shaft direction and angular travel to close.
- Main control actuator (gate or deflector) time: opening and closing.
- Runner blade or nozzle control actuator times : opening and closing.
- Results of turbine “index” tests or model tests, if available.
- Type, size, and any special characteristics of equipment to be supplied with the governor for remote mounting, if required (examples include speed sensors, turbine-control actuator position sensors, switchboard instruments).
- Current carrying capacity and operating rpm of speed and overspeed switches.
- Preferred or required HPSS gas medium.
- Brake actuating medium and pressure.
- Required interfacing for purchaser furnished controls including required electrical ratings.
- Dimensional drawings showing the mechanical interface between existing equipment and new equipment supplied by the manufacturer.
- Special design considerations, e.g., electric governor, joint control, 3D cams.
- Required initial adjustments for selected governor parameters that have a range of adjustment.

- Complete four quadrant prototype turbine data or turbine model data together with model to prototype scaling. These data should cover the range of zero to full gate opening.
- Site specific safety rules and procedures.
- Unit operation conditions (for example, isolated operation, expected load variations, frequency boundaries).
- Unit sequences (for example, special start-up or shutdown sequences, turbine re-start during coast-down).
- Anticipated hydraulic oil specifications, including type and viscosity.
- The authority of jurisdiction regarding pressure tank certification.
- The authority of jurisdiction regarding piping certification (if required).
- Applicable fire regulation codes or standards (if any).
- Other applicable regulatory requirements.

Annex A

(informative)

Bibliography

- [B1] Agee, J.C., Vu, Hoa D., and Volk, James, "Installation and testing of a prototype digital governor at Mt. Elbert Power Plant," IEEE PES Winter Meeting Transactions, Paper no. 0-7803-4403-0/98, 1999.
- [B2] ANSI/ASME Std PTC29-1965 (Reaff 1985), Speed-Governing Systems for Hydraulic Turbine Generator Units.⁶
- [B3] ANSI/ASME Std B31.1-1986 (SI Edition 1983), Power Piping.
- [B4] ANSI Std B93.11M-1981, Seamless Low Carbon Steel Hydraulic Line Tubing.
- [B5] ASME Boiler and Pressure Vessel Code, Section VIII, Rules for Construction of Division 1 Pressure Vessels.
- [B6] Eilts, L.E. and Schleif, F.R., "Governing features and performance of the first 600-MW hydrogenerating unit at Grand Coulee," IEEE Transactions on Power Apparatus and Systems, vol. PAS-96, no. 2, March/April 1977.
- [B7] EN 13445 (2002), Harmonization European Code for Unfired Pressure Vessels.⁷
- [B8] EN 13480 (2003), Harmonized European Code for Piping.
- [B9] IEC 60041 (1991-11), Field acceptance tests to determine the hydraulic performance of hydraulic turbines, storage pumps and pump turbines.⁸
- [B10] IEC 60255-22-1 Ed. 2.0b (2005-03), Electrical relays—Part 22-1: Electrical 163.00 disturbance tests for measuring relays and protection equipment—1 MHz burst – immunity tests.
- [B11] IEC 60255-22-4 Ed. 2.0b (2002-04), Electrical relays—Part 22-4: Electrical 28.00 disturbance tests for measuring relays and protection equipment—Electrical fast transient/burst immunity test.
- [B12] IEC 60255-22-5 Ed 1.0b, Electrical relays—Part 22-5: Electrical 71.00 disturbance tests for measuring relays and protection equipment—Surge immunity test.
- [B13] IEC 60308 (2005-01), Hydraulic turbines—Testing of control systems.
- [B14] IEC 60545 (1976-01), Guide for Commissioning, Operation and Maintenance of Hydraulic Turbines.
- [B15] IEC 61116 (1992-10), Electromechanical equipment guide for small hydroelectric installations.
- [B16] IEC 61362 (1998-03), Guide to specification of hydraulic turbine-control systems.
- [B17] IEEE 100, *The Authoritative Dictionary of IEEE Standards Terms*, Seventh Edition.^{9, 10}
- [B18] IEEE Std 665™-1995, IEEE Guide for Generating Station Grounding.

⁶ ASME publications are available from the American Society of Mechanical Engineers, 3 Park Avenue, New York, NY 10016-5990, USA (<http://www.asme.org/>).

⁷ EN publications are available from the European Committee for Standardization (CEN), 36, rue de Stassart, B-1050 Brussels, Belgium (<http://www.cenorm.be>).

⁸ IEC publications are available from the Sales Department of the International Electrotechnical Commission, Case Postale 131, 3, rue de Varembe, CH-1211, Genève 20, Switzerland/Suisse (<http://www.iec.ch/>). IEC publications are also available in the United States from the Sales Department, American National Standards Institute, 11 West 42nd Street, 13th Floor, New York, NY 10036, USA.

⁹ The IEEE standards or products referred to in this bibliography are trademarks owned by the Institute of Electrical and Electronics Engineers, Incorporated.

¹⁰ IEEE publications are available from the Institute of Electrical and Electronics Engineers, 445 Hoes Lane, Piscataway, NJ 08855-1331, USA (<http://standards.ieee.org/>).

- [B19] IEEE Std 1020™-1988 (Reaff 1994), IEEE Guide for Control of Small Hydroelectric Power Plants.
- [B20] IEEE Std 1248™-1998, IEEE Guide of the Commissioning of Electrical Systems in Hydroelectric Power Plants.
- [B21] IEEE Std 1249™-1996, IEEE Guide for Computer-Based Control for Hydroelectric Power Plant Automation.
- [B22] IEEE Std C37.90.1™-2002, IEEE Standard Surge Withstand Capability (SWC) Tests for Relays and Relay Systems Associated with Electric Power Apparatus.
- [B23] IEEE Std C37.90.2™-2004, IEEE Standard for Withstand Capability of Relay Systems to Radiated Electromagnetic Interference from Transceivers.

Annex B

(informative)

Glossary

damping: A measure of the stability of a closed-loop control system when recovering from a transient disturbance and returning to steady-state operation. Damping increases with the value of the damping ratio. A damping ratio of 1.0 or greater is highly damped, and exhibits no oscillatory action when recovering from a transient disturbance. A damping ratio between 0.0 and 1.0 is “under damped” and exhibits some decaying oscillatory action when recovering from a transient disturbance. A damping ratio of 0.0 or less exhibits continuous oscillatory action, and will not achieve steady-state operation.

distributing valve: The element of the turbine-control actuator that controls the flow of hydraulic fluid to the turbine-control actuator(s).

source code: The software that defines the control sequence/strategy for a specific installation. It may be ladder logic, function block code, sequencing logic or a similar type of software code. In some cases, it may be a simple settings file. The source code resides in the memory of the programming computer.

Annex C

(normative)

Mode control logic

C.1 Droop mode control logic

Some specifiers require both speed droop-position (position feedback) and speed droop-power (or speed droop-flow) including a means of automatically transferring between these two modes of operation. The automatic transfer is typically based upon operator selection, feedback signal quality (for example, power or flow signal is good or signal is failed) and possibly whether the turbine-generator is operating grid connected, islanded or isolated. The mode transfer method should be specified. Figure C.1 illustrates a typical logic implementation.

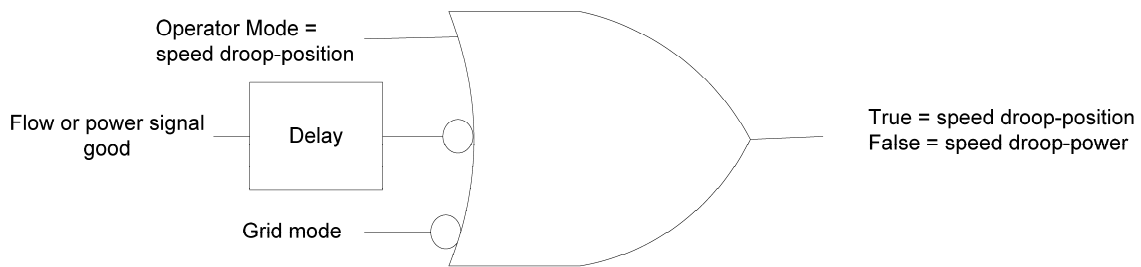
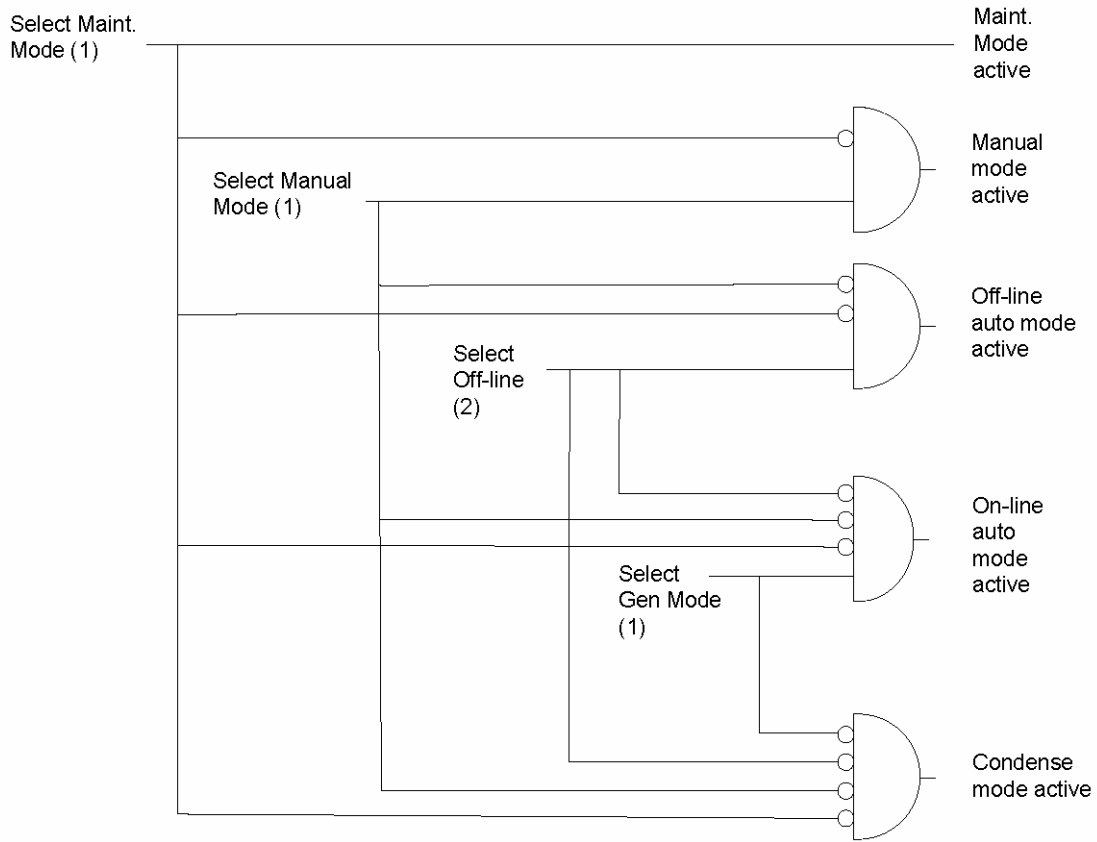

Figure C.1—Droop mode control logic

C.2 Governor mode control logic

The logic should be designed such that certain modes of operation take priority over other modes. As well, the logic should ensure that there is always one mode selected, regardless of the states of the mode selection inputs (i.e., the situation where no mode is selected must be avoided). Figure C.2 shows one method of achieving this design criteria.



(1) Operator selection

(2) Typical logic includes generator circuit breaker status, automatic isolation detection

Figure C.2—Governor mode control logic

Annex D

(normative)

Tables

Table D.1 provides a list of typical input and output quantities and alarms that may be specified to be incorporated into the governor to allow interface with the operator interface as described in 5.1.4 and the interface with other plant systems described in 5.1.3.

Table D.1—Typical local and remote control and display quantities

Description	Control (note 1)	Analog (note 2)	Status (note 3)	Alarm or shutdown	Comment
Emergency shutdown	x			x	should be hardwired (i.e., not implemented exclusively through an OIT)
Local/remote transfer	x		x		Implies unit local/remote status
Power, servo position, flow or pond level adjust	x				
Speed adjust	x				
Servo Limit Adjust	x				Gate limit for reaction turbine, nozzle limit for impulse turbine
Speed droop adjust	x				
Manual/auto transfer	x		x		Implies unit manual/auto status
Creep enable	x		x		
Creep reset	x			x	
Alarm reset	x				
Governor Start/stop	x				
Isolated Operation on/off	x		x		Required only for units expected to operate isolated from the grid
Fast breakaway on/off	x		x		for rapid gate or nozzle opening rate at start-up
Reservoir level control on/off	x		x		
Nozzle sequencing on/off	x		x		for impulse turbines
Water waste mode on/off	x		x		for impulse turbines
Damping parameters adjust	x				Gains, time constants, etc.
Generator brake on/off	x		x		
Net head or static head level		x			Used for optimum blade positioning and optimum pumping unit gate position
Active power		x			
Main servo position		x			Gate position for reaction turbine, deflector position for impulse turbine
Nozzle servo position		x			Impulse turbines – 1 for each servo
Brake air pressure - supply		x			

Table D.1—Typical local and remote control and display quantities (continued)

Description	Control (note 1)	Analog (note 2)	Status (note 3)	Alarm or shutdown	Comment
Brake air pressure - applied		x			
Sump oil level		x			
Sump oil temperature		x			
HPSS pressure		x			
Accumulator oil level		x			
Speed		x			
Penstock pressure		x			
Draft tube pressure		x			
Turbine runtime		x			Elapsed turbine operating hours
Condensing runtime		x			For turbine-generator units with synchronous condense capability. Elapsed hours in condense mode
Cavitation zone or rough zone runtime		x			Elapsed turbine operating hours in cavitation or rough zone. Typically a pre-defined zone (or multiple zones) of gate opening
Governor start/run state			x		Deadstop, starting, synchronizing, on-line, stopping, etc.
Governor gains			x		Off-line/On-line Grid/On-line isolated
Fast breakaway on/off	x		x		Optional feature
Reservoir level control on/off	x		x		Optional feature
Nozzle sequencing on/off	x		x		Optional feature for impulse turbines
Water waste mode on/off	x		x		Optional feature for impulse turbines
Generate/condense mode	x		x		
Droop mode	x		x		Power, servo position or flow feedback
Servo lock applied /released			x		
Shutdown solenoid On/off			x		
Governor auto/manual	x		x		
Brakes manually or mechanically applied	x		x		
Pump run/stop			x		For each pump
Pump lead/lag	x		x		For each pump
Pump auto/manual	x		x		For each pump
Power, position or flow set point at upper limit			x		
Power, position or flow set point at lower limit			x		
Speed set point at upper limit			x		
Speed set point at lower limit			x		
Power, position or flow at set point			x		
Speed at set point			x		
Speed No Load			x		
Breaker open/closed status			x		
Control actuator limit coincidence			x		Indication that the main servo has

Table D.1—Typical local and remote control and display quantities (continued)

Description	Control (note 1)	Analog (note 2)	Status (note 3)	Alarm or shutdown	Comment
					reached the gate limit (reaction turbines) or nozzle servos have reached the flow limit (impulse turbines)
Turbine shutdowns				x	See 5.2.15 for typical shutdowns
Servo lock fail to apply				x	
HPSS lag pump running				x	
HPSS low pressure				x	
HPSS accumulator low level				x	
HPSS accumulator high level				x	
HPSS filter plugged				x	
HPSS sump low level				x	
HPSS oil high temperature				x	
Air brake pressure low				x	
Creep				x	
HPSS accumulator air relief operation				x	
Speed signal failure				x	
Power transducer failure				x	
Loss of Control Power				x	
Lockout				x	
Over-speed				x	
Watch Dog Timer				x	
Gate Run Control Relay Monitor			x		
Gate Reset Control Relay Monitor			x		
Gate Shutdown Control Relay Monitor			x		
Blade Reset Control Relay Monitor			x		
Blade Shutdown Control Relay Monitor			x		

NOTE 1—Control used in this column is intended to encompass the inputs to the operator interface, or conventional controls and indicators, or interface with other plant systems (for example, supervisory or plant control system) that may be necessary to affect control actions.

NOTE 2—Analog quantities derived from direct measurement may be measured by either an analog transducer or a digital transducer.

NOTE 3—Status quantities may be either two-state (for example, on/off) or multi-state (for example, stopped/starting/running/stopping).